

BEMMO



FAÇADES

VARIETY



METAL FAÇADES



NATURE IS THE BEST MODEL – THE BEST ENGINEERING “MADE IN GERMANY”



The leaf is the archetypal form of roof. Its shape is the only right one for the particular place where it grows. Its sustainable design is matched perfectly to the respective environmental conditions. Its richness of variety inspires the observer to give his imagination full reign.

BEMO PRODUCTS ARE BASED ON THE GREATEST ARCHITECT OF ALL TIME: NATURE.

The BEMO leaf is therefore the outwardly visible symbol of a powerful brand name for extraordinary buildings and exceptional solutions for roofs and façades.

In addition to the highest quality, we pay close attention to long-life and recyclability when selecting materials. Our mobile production lines can be used anywhere in the world, thereby significantly reducing transport costs and corresponding emissions. Using our patented production method, we create shapes that give planners and architects the freedom they need to break away from conventions.

An unequalled choice of combinations of materials, surfaces and colours is the reason why we are able to reproduce Nature's rich variety in architecture.

Our 3D software, developed in-house, supports you in planning and measuring the supporting structure through to the design of the substructure, thus ensuring high quality without any unpleasant surprises. “German Technology” in production and the countless number of possible combinations of available surfaces, materials, shapes and colours mean that practically any design idea can be implemented.

That is how we get close to our ideal: Nature.



6
FAÇADE SYSTEMS



8
PRODUCT VARIETY



14
ENGINEERING

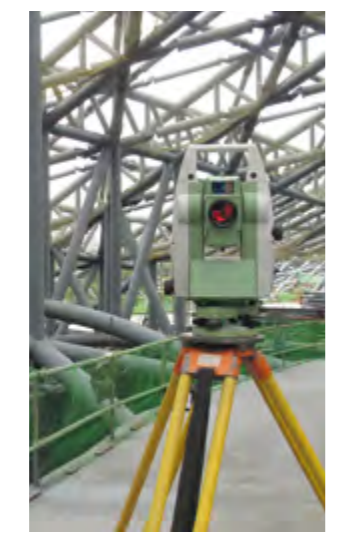

16
BOQ SERVICE

10
SERVICE



BEMO – YOUR SUPPLY CHAIN PARTNER

12
ADVISORY SERVICE



18
STRUCTURAL ANALYSIS AND BUILDING PHYSICS



20
BACK-VENTILATED CURTAIN FAÇADE

26
BEMO-BOND COMPOSITE PANELS



32
BEMO FAÇADE PANELS

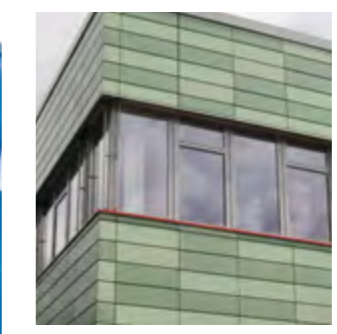

42
BEMO CORRUGATED PROFILES



38
BEMO STANDING SEAM



46
BEMO TRAPEZOIDAL PROFILES



GIVE YOUR BUILDING THE RIGHT LOOK – WITH BEMO



The façade of a building isn't merely a form of protection; in fact, it expresses so much more: design, perceived values, emotion and, of course, the corporate identity of a company. Added to these are technical requirements such as wind tightness, optimised thermal insulation and moisture protection. Using the unique BEMO variety of materials, surfaces, colours and shapes, façades can be designed exactly to your requirements. BEMO substructure systems are suited to every sub-surface, compensate tolerances and satisfy the latest requirements in terms of engineering and building physics in a very special way.

VARIETY IN DESIGN – PERFECTION IN IMPLEMENTATION.

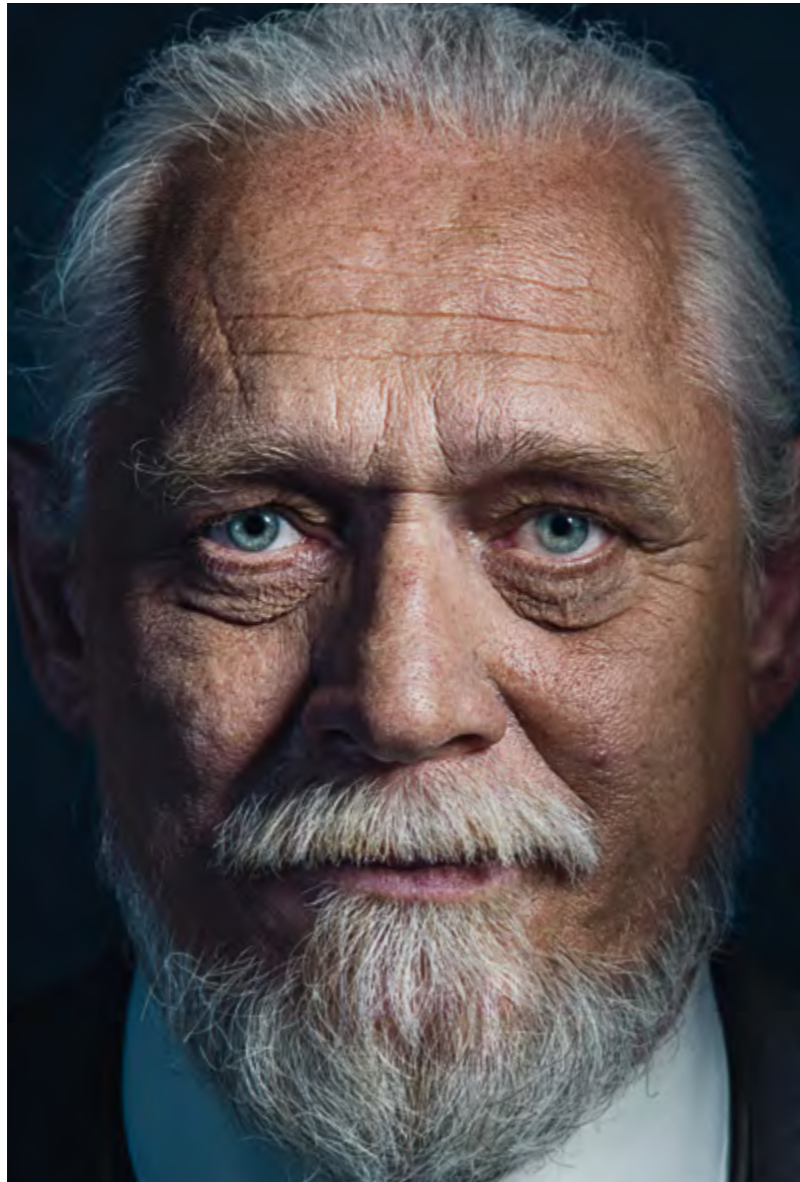

DURABLE AND RECYCLABLE
... by using metal and recyclable plastic your project will become a source of materials for the future.



IT DOESN'T ALWAYS HAVE TO BE BRIGHT AND COLOURFUL
... use natural metal surfaces in aluminium, stainless steel or copper, for example, to set highlights.

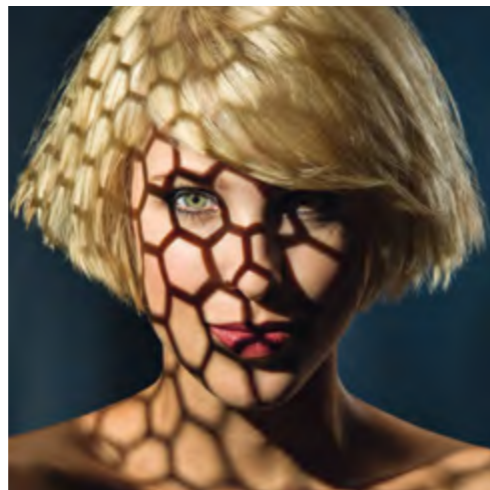

BRING YOUR FAÇADE TO LIFE
... with perforated façades for a dramatic play of light and shadow.

A FAÇADE HAS MANY FACETS – WITH BEMO'S PRODUCT VARIETY



AN ENDLESS VARIETY OF COLOURS
... with over 40,000 colours already available and a colour laboratory to give you more freedom of choice.



THERMAL BRIDGE-FREE SUBSTRUCTURE
... for up to 75% improved OHTC for your façade.



CHOOSE THE RIGHT PARTNER AND YOUR PROJECT IS A SURE SUCCESS



Every project starts with an idea, a vision or a first draft. But the route to implementing it is often long and requires reliable, strong partners to provide professional support in all phases of the project. From the initial consultation when choosing materials and design, the first technical specifications and structural pre-analysis – BEMO and its experienced team of experts is always there for you, wherever you may need us.

TECHNICAL ADVICE AND ECONOMIC FEASIBILITY AS THE BASIS.

Cost estimates, technical optimisation or calculating alternatives help you to optimise the economic feasibility of your project and ensure cost certainty. That is what we mean by a comprehensive partnership with BEMO.



GOOD SERVICE STARTS WITH OBJECTIVE ADVICE AND ONLY ENDS WHEN THE PROJECT IS COMPLETED



SYSTEM CONSULTING:

As an experienced international manufacturer of high-quality roof and façade systems, our very extensive expertise is at your disposal when addressing complex tasks for your projects. Our in-house planning office with its team of experienced civil and structural engineers, 2D and 3D planners as well as “hands-on” professionals are at your service, also in the design and pre-planning phase, together with our long-standing partners responsible for execution. BEMO is at your side in all phases of your project.

BASIC TECHNICAL EVALUATION:

Before you issue calls for tenders, we will be happy to discuss technical details, structural pre-analysis and structural solutions with you. Whether the interspaces in the substructure, the number of wall consoles per m² or the exact calculation of OHTC and all relevant thermal bridges: for us this is always the foundation for every call for tenders. Our team of professionals specialises precisely in this type of work.

TENDER SERVICE:

A good, detailed and correct call for tenders gives all parties involved in the project cost certainty and planning reliability, a high level of transparency and later ensures the construction project is completed to the satisfaction of all. We will be happy to take on this task for you or compile the necessary preliminary information.

CONSTRUCTION SITE SUPPORT:

The demands on companies executing projects increase with the complexity of buildings, geometry and ever-increasing requirements for documentation. BEMO technical staff are well experienced in construction site conditions and are happy to be “on site” with our installation partners, giving advice, practical support as well as supplying sophisticated system components, some of which are pre-assembled.



Ferrari dealership // Austria
Architect: Götz Seidel & ATMOS Architekten ZT OG
Photo: Mili Martinez-Flener/vor-ort-foto.de



BEMO ENGINEERING

FROM BOQ THROUGH TO COMPLEX 3D PLANNING



No matter whether simple details and drawings are needed or highly complex 3D plans – we are well equipped to deliver, no matter what your requirements. Our specialists for 3D thermal simulation can calculate optimised structures, including all thermal bridges.

THE NO-WORRY PACKAGE FOR BEMO SYSTEMS.

As-built structural analysis on site and exact planning of the necessary tolerance compensation, preparation of installation plans and assembly plans... all these are services offered by our in-house planning office.



BEST TECHNICAL SUPPORT

 **VISUALISATION:**
Design ideas, initial drafts or drawings can help to transform visions. But if you want to transform a 1:1 model or an idea into reality, a 3D rendering will help. We will be happy to prepare one for you.

BOQ SERVICE:
A 3D scan lends itself to more complex structures and building geometry, defining contours to the millimetre and providing implementation planners with the perfect foundation. This saves time later when executing the project. Perfect 3D plans are the standard today and are essential for integrated overall plans.

PLANNING SERVICES:
Independent of the complexity of the project – BEMO offers the right scope of planning for every level of difficulty and requirement. Cost-effective and professional. For roofs and façades. With proof of structural analysis and building physics.



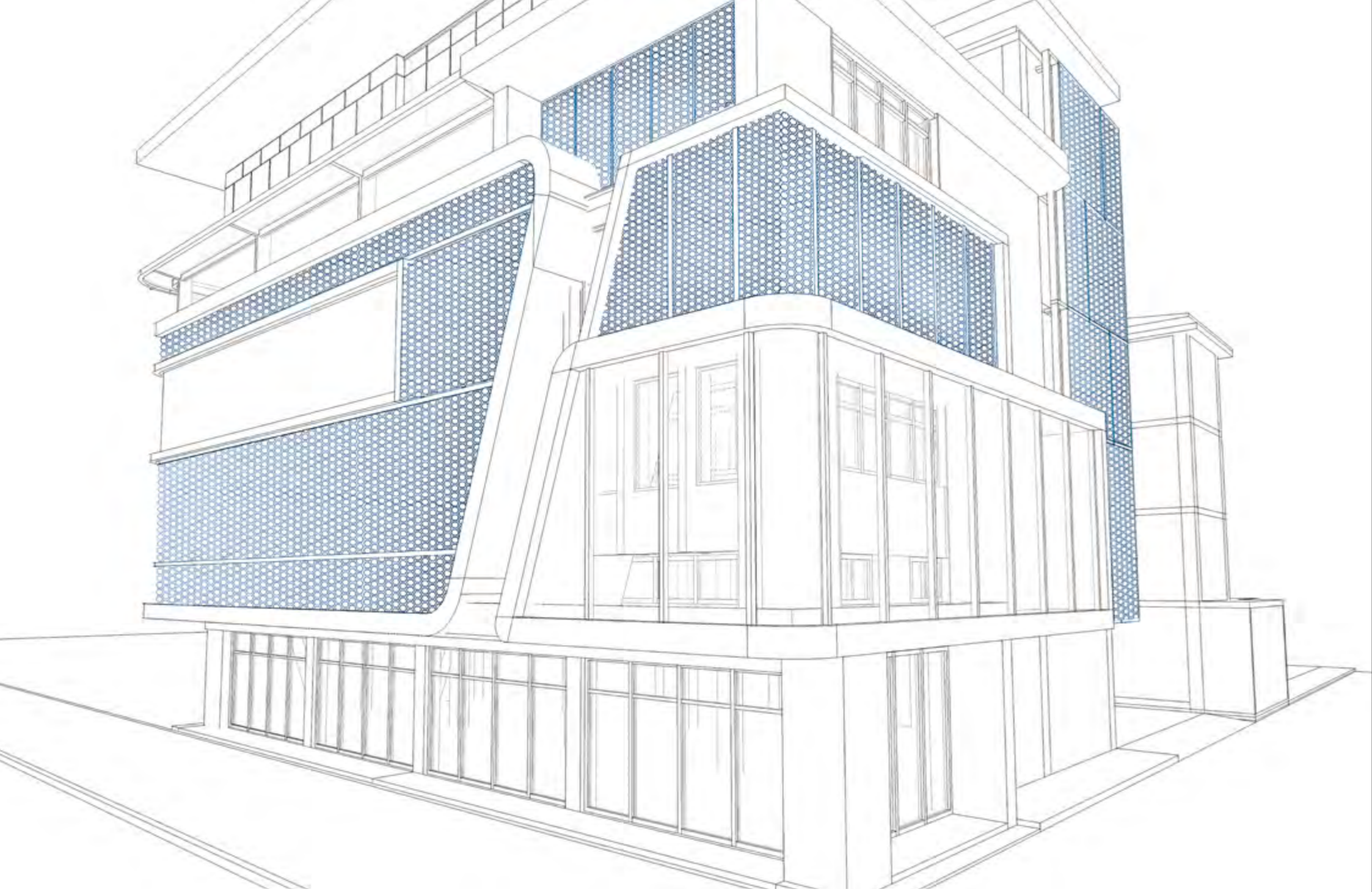

CALCULATIONS ON A SOUND BASIS – OUR EXPERIENCE

STRUCTURAL CALCULATIONS / STRUCTURAL SOLUTIONS:
 Every building, every superstructure and every design requires proof of structural soundness based on standards, system approval or simply on the basis of historical data collected. The range of requirements is extensive. European standards are often difficult to understand and keep abreast of. That is why it is all the more important to have a professional, reliable systems partner who is familiar with requirements and structural conditions and can do the necessary calculations himself. At BEMO we can do that for you.

PROOF OF BUILDING PHYSICS:
 The interaction of the requirements of structural analysis and building physics and customers' preferences can be challenging at times. It is exactly at this point that BEMO can offer solutions and approaches that take all requirements into account. Using tried and tested system solutions. Using special solutions based on experience.

Proof of building physics rounds off our "Engineering" service package. Take advantage of our experience, our calculation tools and our knowledge built up over years of practical implementation. Soundproofing, thermal and moisture insulation are in good hands at BEMO.

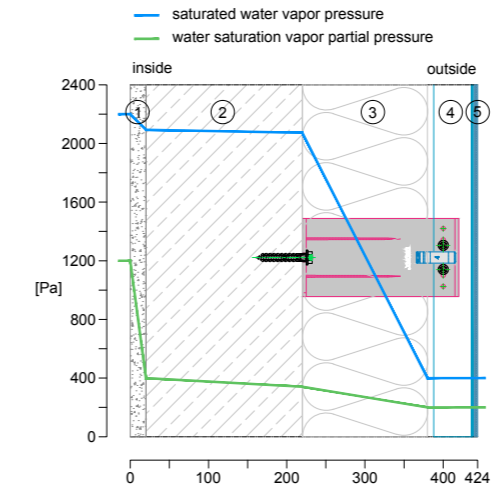
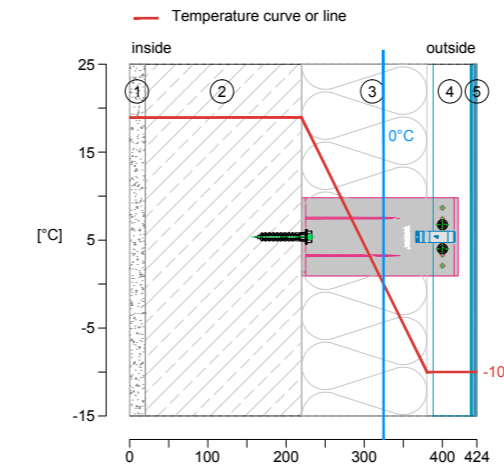



CURTAINWALL – THE PERFECT SOLUTION FOR FAÇADES



Systems are the interaction of several components that are perfectly designed and harmonise with each other. Interaction of the right components ensures safety and provides comprehensive, normally tested and documented performance criteria.

A back-ventilated curtain façade system is such a system: Optimum building physics. Safe structures. Flexible visual design and adaptable to practically all needs. Satisfies the latest fire protection requirements, also for multi-storey buildings, and ensures maximum performance in terms of moisture proofing. The back ventilation level ensures that moisture diffused through the constructional element is “removed” regularly so no moisture damage can occur.

CURTAINWALL – OPTIMUM BUILDING PHYSICS – WITH MAXIMUM FREEDOM OF DESIGN.

The anchor surface (concrete, masonry, wood, etc.) can differ. The design options are sheer limitless thanks to the wide variety of covering products from BEMO. The BEMO-TEKOFIX console rounds off our back-ventilation system with a thermal bridge-free substructure for up to 75% better insulation performance of the whole system.



THERMAL BRIDGE-FREE WITH TEKOFIX – MAXIMUM FIRE PROTECTION WITH STAINLESS STEEL

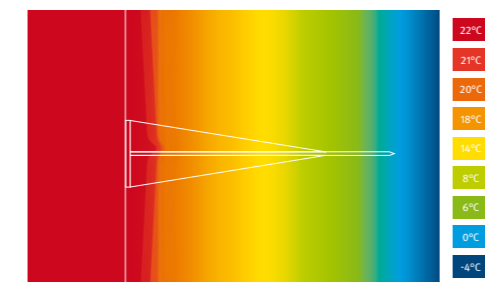

THERMAL BRIDGE-FREE:

In terms of energy, every wall structure is only as good as the thermal insulation installed. However, linear, punctiform and of course material-related thermal bridges lower the insulation performance of every insulation material. Only substructures with low thermal conductivity can reduce these system-related thermal bridges. If possible, linear substructures should be avoided completely.



TEKOFIX:

The TEKOFIX console is used for wall structures with thermal insulation and which have to satisfy high or the very highest energy requirements. It offers up to 430 times less thermal conductivity than metal-based materials. It has been proved that the installation of TEKOFIX can mean energy savings of up to 75%. The thickness of the wall structure is reduced significantly with TEKOFIX. Connections at windows and doors and the whole installation process are simplified greatly, ensuring full cost optimisation. The TEKOFIX console meets Passive House standards.



STAINLESS STEEL SUBSTRUCTURE:

The ideal solution to satisfy the most stringent fire protection requirements. The stainless steel consoles are installed at selected points and, thanks to their relatively low thermal conductivity, they offer low OHTC. Since stainless steel is not flammable, more stringent fire protection standards can be achieved using these consoles. We will be happy to carry out all calculations on building physics and determine the effective OHTC, including thermal bridges at selective points caused by the metal consoles.

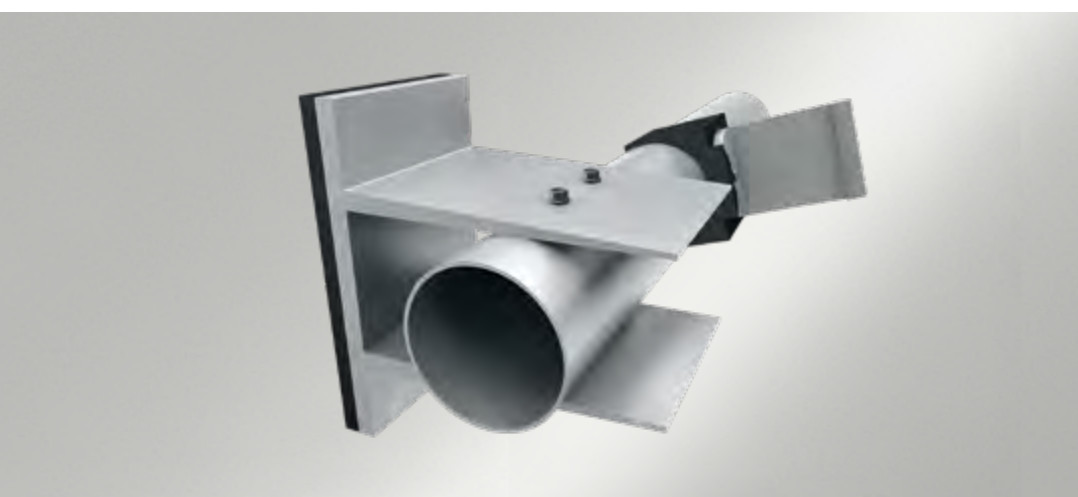

BEMO-DOME SUBSTRUCTURE: FOR FAST, EASY AND HIGHLY FLEXIBLE INSTALLATION



The BEMO-DOME substructure offers a highly flexible substructure solution that is right for cylindrical building shapes or those curved around 2 axes. Covering options range from metallic trapezoidal and corrugated profiles through to conical or free-form BEMO-MONRO tracks.

Whether for a wall structure with or without back ventilation, BEMO-DOME substructure satisfies every requirement. In order to achieve perfect results, for this substructure system we recommend carrying out a 3D scan for on-site BOQ and 3D installation plans.



BEMO-BOND – FAÇADE COVERING AT THE VERY HIGHEST LEVEL

BEMO-BOND – FAÇADE COVERING WITH LIMITLESS SCOPE FOR DESIGN

Aluminium composite panels as a premium-quality façade covering for back ventilation façades BEMO-BOND can be used in a wide range of applications. With visible and invisible fastenings – freely configurable, varying panel sizes from 6000 mm x 2000 mm – with a large range of colours and individually configurable, detailed solutions.

Perforated elements, backlit on request, the option to integrate lettering, emblems or logos – BEMO-BOND composite panels offer sheer limitless possibilities. Also available as a non-flammable composite panel with A2 construction product classification.



Closed edge



Perforated



Corner lipping



BEMO-BOND INVISIO



Rounded panels



BEMO-BOND FAÇADE COMPOSITE PANELS



The BEMO-BOND panel is available in the whole range of BEMO colours – also with the option to mix your own colours in the BEMO colour laboratory. Matching fastenings and flashings can be ordered and supplied with the same batch.

BEMO-BOND composite panels are – depending on the fastening system used – available in sizes up to 6000 mm x 2000 mm.

Fastenings can be visible, e.g. screws or rivets in the same colour as the panels. Hidden or invisible fastenings can come as cassette systems or using the new, innovative system BEMO-BOND INVISIO.

As an option, closed exposed edges seal the panel core for a panel finish in the same colour as the panel surface.

The panels are processed in our in-house BEMO processing centre; this can also include BEMO installation planning. The panels are pre-machined according to requirements for just-in-time delivery to the project.

Fire classifications include B-S1, d0 and A2-S1, d0. Panels are available in thicknesses of 4 mm or 6 mm.

Façade composite panels	
Approval number	Z-33.2-1559
Outer coating	BEMO-FLON
Covering sheet	Two aluminium covering sheets, each 0.5 mm, EN AW-3105 or 3005 alloy
Core	polyethylene / inorganic filler material
Format sizes	b: 800 – 2000 mm, l: to 7200 mm
Perforation Pattern	Press cuts up to max. 45% perforation
Weight	Polyethylene: 7.6 kg/m ² / inorganic filler material: 8.1 kg/m ²
Flammability rating according to DIN EN 13501-1	B-s1, d0 / A2-s1, d0



Panel screwed

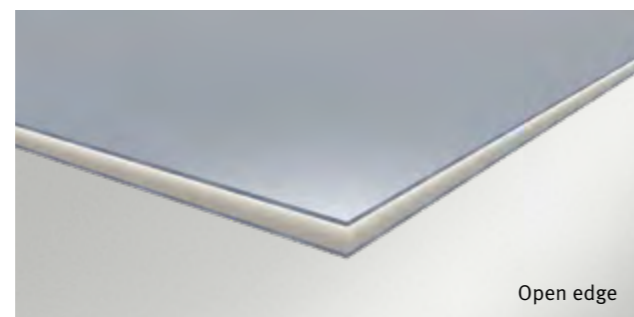

Open edge

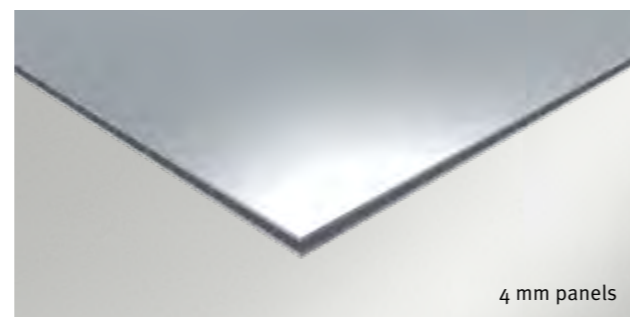

4 mm panels



Panel riveted

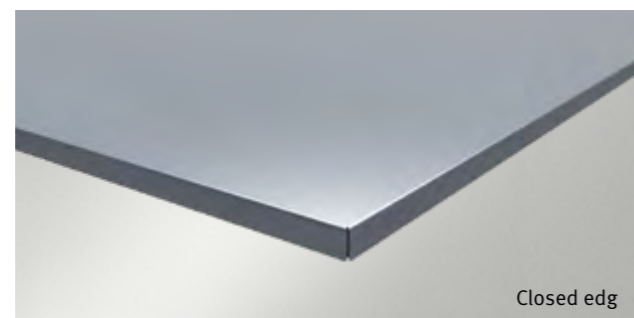

Closed edge

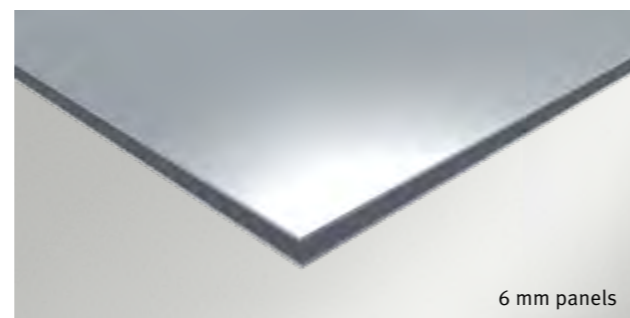

6 mm panels



BEMO-BOND INVISIO – AN INNOVATION IN FASTENINGS SYSTEMS



THE PERFECT FASTENING SYSTEM FOR COMPOSITE PANELS:

Invisible. Aesthetic. Cost-effective.

Allows year-round processing independent of the weather and offers the possibility of making fine adjustments during the final installation. These are just a few of the advantages of the BEMO-BOND INVISIO system.

The system offers architects and designers the possibility of using very large panel sizes (up to 6000mm x 2000mm) with near-invisible seams. The linear expansion of panels is compensated through the sliding fastenings to substructure rails. Seams running around the edges of the panels can have the same colour for durable, secure seams.

High-quality, perforated panels and closed exposed edges as well as perfect corner and jamb lipping round off the high-quality appearance of BEMO-BOND façades.

Of course, BEMO-BOND INVISIO is also available in rounded panels with large radii.

BEMO-BOND INVISIO

Approval number	Z-33.2-1559
Material	Aluminium with BEMO-FLON coating
Total thickness of BEMO-BOND	4.0 mm / 6.0 mm
Covering sheet	Two aluminium covering sheets, each 0.5 mm, EN AW-3105 or 3005 alloy
Core	3 or 5 mm polyethylene core, 3 mm inorganic filler material core
Maximum format sizes	installed vertically: 2000mm x 4000mm, horizontal max. 2000mm x 7000mm
Flammability rating according to DIN EN 13501-	Polyethylene: B-s1, d0 / flame resistant (standard) inorganic filler material: A2-s1, d0**, not flammable
Special features	Clip and substructure intervals are determined on the basis of the structural analysis.

** not in-stock goods; deliverable on a project basis.

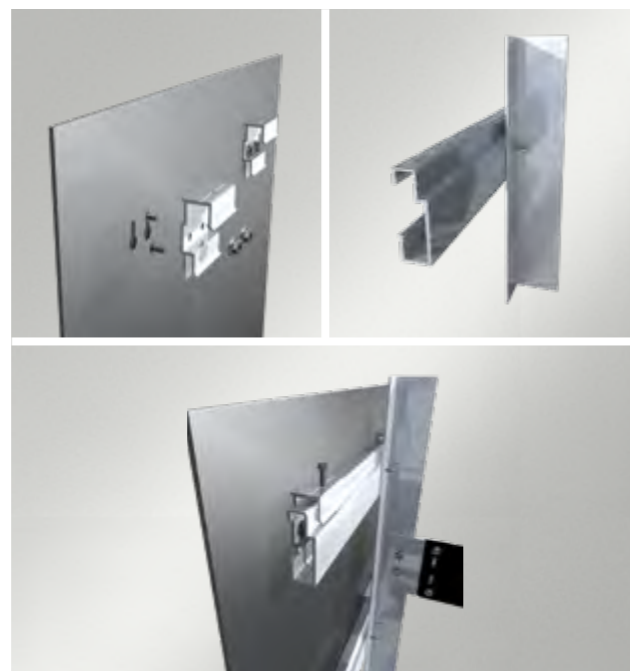



Secondary school Hermann-Billing-Gymnasium // Germany
 Photo: vor-ort-foto.de

**FAÇADE PANELS –
 ENDLESS VARIETY**

**BEMO FAÇADE PANELS – FOR INDIVIDUAL
 AND – SHEER LIMITLESS DESIGN**

BEMO façade panels made of metal – for individual, free-form façade design. Horizontal, vertical or diagonal. Fastenings can be hidden, visible or slide freely for hanging, depending on requirements and individual circumstances. The right solution for every application. Surfaces and colours can be selected and combined freely.

Individually configurable panels with free-form profile geometry are the absolute highlight. Profile height and spaces can be configured freely and flexibly. Grid dimensions can be selected freely in combination with the necessary material thickness for perfect results.

OUR BEMO PROJECT ADVISERS WILL HELP YOU TO CHOOSE THE OPTIMUM PRODUCTS IN THE DESIGN AND PLANNING PHASE.



Box panel Slot-in panel Sliding panel ZP 35-800 Special panels PRIMO clip-on façade



BEMO FAÇADE PANELS

➤ COST-EFFECTIVE AND AESTHETIC METAL.

BEMO façade panels can be made of almost all types of metal materials. With numerous types of surface. With a sheer limitless colour range. With standard grids or individually designed. Depending on the type, panels can be mounted vertically, horizontally or diagonally. With visible or invisible fastenings. Naturally customers can combine different panel optics in one direction of installation or arrange them in a staggered pattern. Panels can be perforated, rounded or crafted as cone-shaped elements.

We will be happy to help you design your BEMO panel façade using the ideal combination of materials.

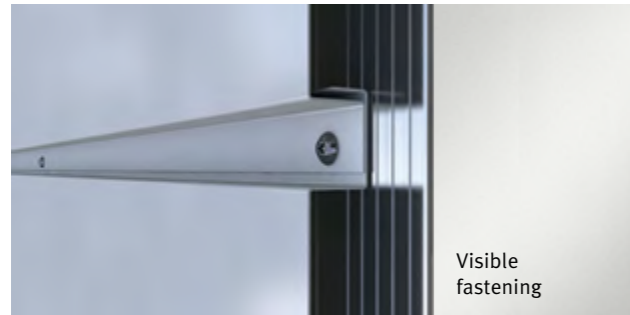

Visible fastening

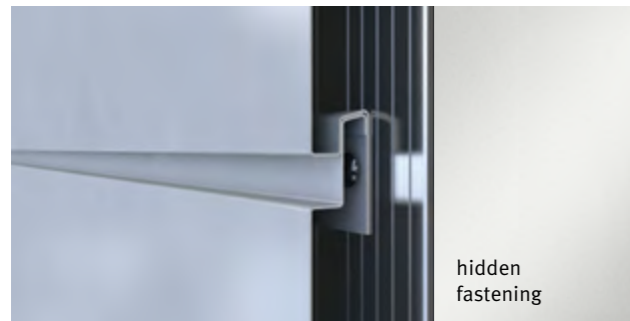

hidden fastening



PRIMO clip-on façade

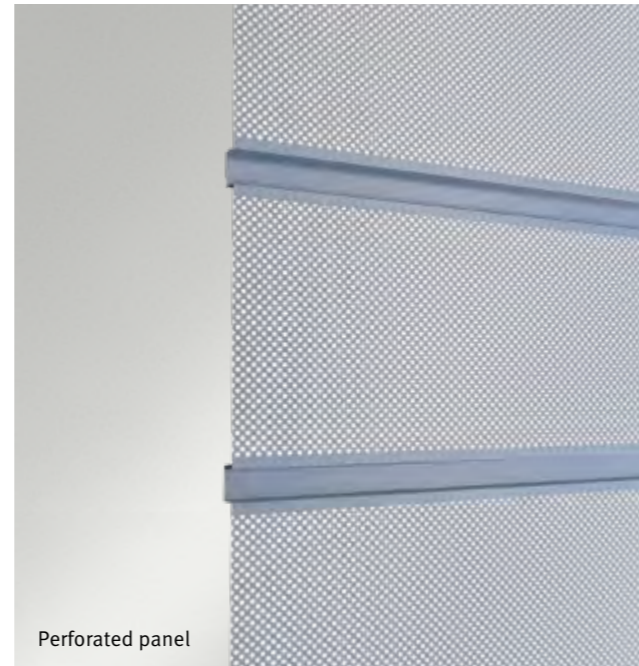

Perforated panel

Façade panels

		Box panel	Slot-in panel	Sliding panel	ZP 35-800	individual panels
Material thickness in mm	Steel	0.75-1.5	0.75-1.0	0.75-1.0	-	0.75-1.0
	Aluminium	0.9-2.0	0.9-1.5	0.9-2.0	0.9-1.5	1.0-1.5
Coatings	PE / PVDF / BEMO-DUR / BEMO-FLON					
Surfaces	Brushed / Aluzinc / pre-weathered / cladded					
Max. length	8.00 m					
Perforation patterns	Rv 3.00-5.00			Rv 3.00-5.00		
Material	Aluminium					
Material thickness in mm	0.9-2.0					



BEMO PRIMO CLIP-ON FAÇADE – HIDDEN FASTENING WITH MAXIMUM GRID SIZE



THE OPTIMUM SOLUTION FOR LARGE-SCALE DESIGN FAÇADES:

A PRIMO clip-on façade is the optimum façade solution for high-quality industrial and commercial buildings – with great scope for design. Grid dimensions can be freely selected between 200 mm and 800 mm – also as a combination of different grid dimensions. The PRIMO substructure can be installed on any base or any substructure – whether concrete, wooden, coffer structures or a mixed base.

Using a new type of fixed point assembly panels can also be removed and replaced after installation. This is an important plus for industrial and commercial façades in the transport sector. Linear expansion is not subject to any constraints and is permanently and fully stress-free. This ensures premium-quality appearance of the façade.

The final assembly of the panels using the clip-on process is fast and cost-effective. Starting, end and special panels round off the PRIMO range. Corner and jamb lipping round off the premium-quality appearance of PRIMO clip-on façades.



PRIMO fixed point clip FIX

PRIMO fixed point clip FIX-S

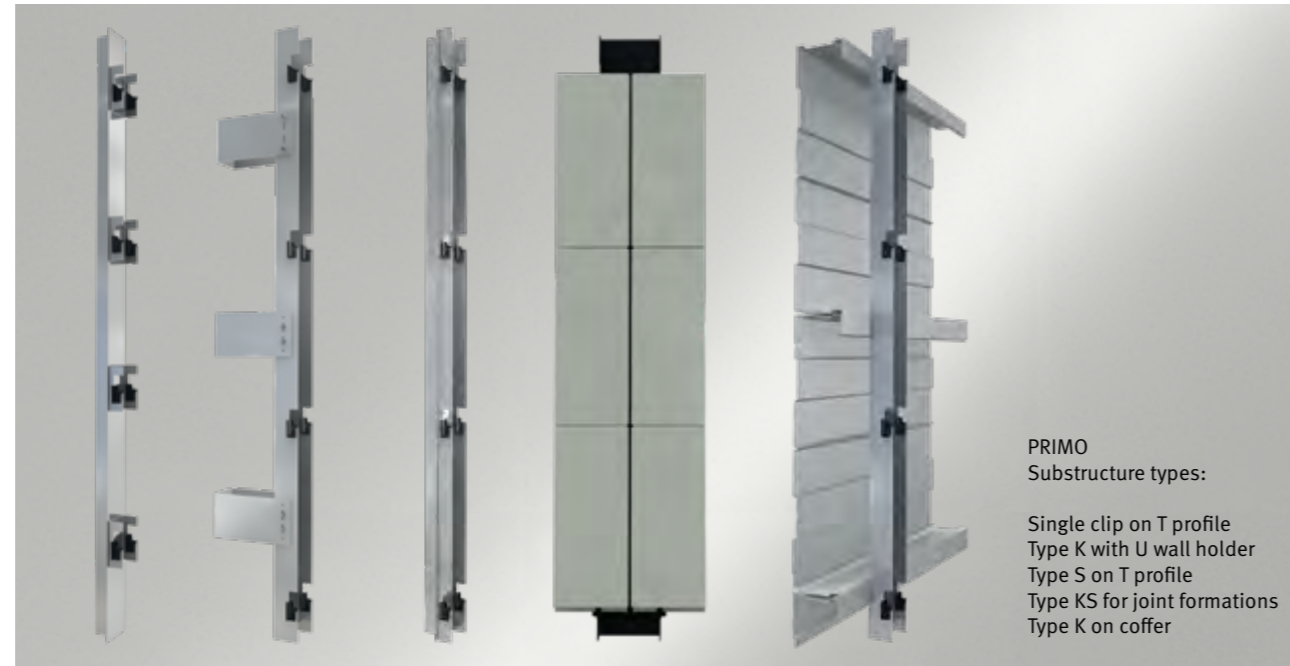

PRIMO Substructure types:

- Single clip on T profile
- Type K with U wall holder
- Type S on T profile
- Type KS for joint formations
- Type K on coffer

Installation video



Scan QR code and look at the installation video
<https://www.youtube.com/watch?v=pAIAYNjAhrE>

PRIMO clip-on façade

Grid dimension		200-400	500	600	800
Material thickness in mm	Steel	0.75-1.5	1.25-1.5	1.25-1.5	1.5
	Aluminium	0.9-1.2	1.2-2.0	1.5-2.0	-
Coatings	PE / PVDF / BEMO-DUR / BEMO-FLON				
Surfaces	Brushed / Aluzinc / pre-weathered / cladded				
Max. length	8.00 m				
Perforation patterns		Rv 3.00-5.00		Rv 5.00-8.00	
Material	Aluminium				
Material thickness in mm	0.9-2.0				

PSV sports hall Salzburg // Austria
Photo: Peter Heimpel / PH-foto.de

BEMO STANDING SEAM – PERFECTION MATCHED WITH MAXIMUM SAFETY

BEMO STANDING SEAM – ROUND, MULTI-DIMENSIONAL, FREE-FORM – SIMPLY EXTRAORDINARY

Some architects and builder-owners expect more than just a square box. Free forms. More design. Flowing transitions from the roof to the façade. Functionally necessary or architecturally desirable cylindrical and 3-dimensional building shapes. Very long individual tracks without transverse overlaps. Or quite simply something other than flat.

BEMO standing seam façades are the perfect solution. BEMO standing seam façades offer numerous advantages with a variety of different systems. For new builds or for façade renovation. For almost every shape of building. Available in numerous metal materials.

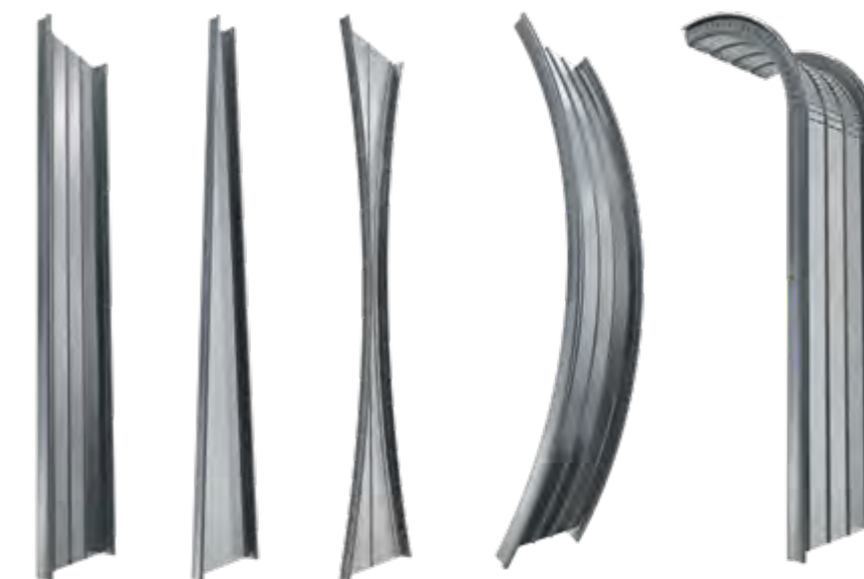

Straight

Conical

Free-form
BEMO-MONRO

Curved

Crimp-curved



BEMO STANDING SEAM – AMAZING FEASIBILITY



THE NUMEROUS BENEFITS:

The BEMO standing seam system also offers unimagined possibilities for façade design. Varying profile widths from 100 mm to 800 mm, 2 profile heights, almost endless panel lengths, parallel, conical and “free-form” profiles give architects, designers and planners the widest range of options. The materials used are normally aluminium or steel, but can also be stainless steel, zinc or copper. The radii for arched profiles start at 600 mm, depending on the design.

Convex and concave radii are possible. The impermeable and hence invisible fastenings satisfy the most sophisticated expectations while ensuring maximum safety. Linear expansion along the system halter is unproblematic, permanent and ensures a long service life. Thermal bridge-free BEMO standing seam halter optimise thermal insulation with a simple system configuration. The standing seam system is rounded off by highly flexible, cost-effective BEMO substructure systems for optimum tolerance compensation for every shape of building. And of course it is complemented by our BEMO engineering and planning team.

BEMO standing seam

Profile types	N50		N65		
Profile widths	333 mm, 429 mm, 529 mm, 600 mm		305 mm, 333 mm, 400 mm, 500 mm, 600 mm		
Variable profiles	from 100 mm		from 100 mm		
Materials	Aluminium	Steel	Stainless steel	Copper	Titanium zinc
Material thickness in mm	0.8–1.2	0.63–0.75	0.6–0.7	0.8–1.0	0.7–1.0
Coatings	BEMO-FLON / PVDF / Polyester				
Surfaces	Stucco / brushed / Aluzinc / pre-weathered / cladded				
Production lengths	factory production up to 38 m, on-site production > 38 m				
Perforation patterns	Rv 3.00–5.00	Rv 3.5–5.00	Rv 5.00–8.00	SW 11-14	
Material	Aluminium				
Material thickness in mm	1.0–1.2				

Building authority approval
 Z-14.1-182 BEMO-FLAT-ROOF aluminium standing seam profile roof elements
 Z-14.1-640 BEMO-FLAT-ROOF standing seam profile roof elements also available in steel: FM approvals, ASTM, BBA certificate, Avis Technique, GOST

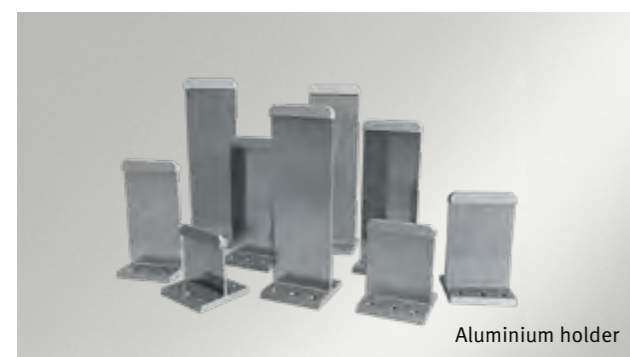
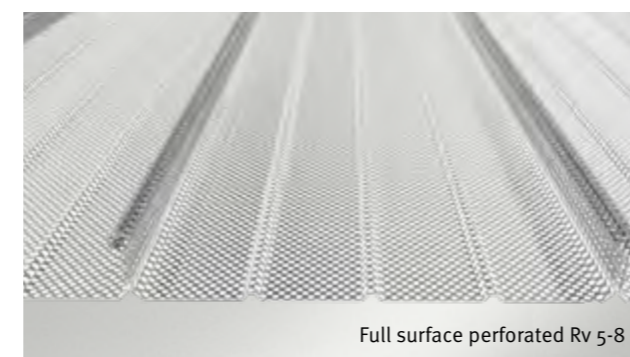
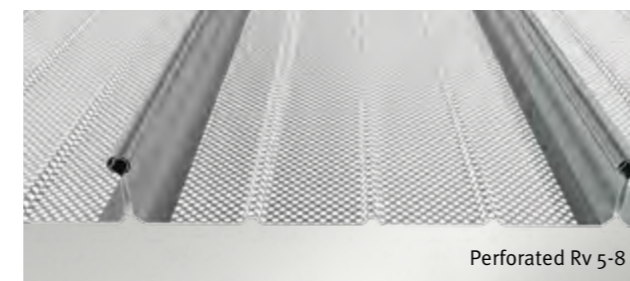
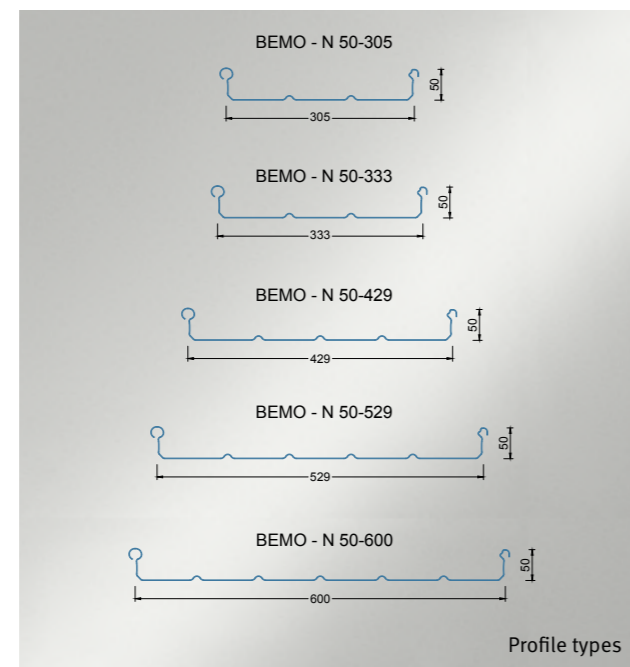
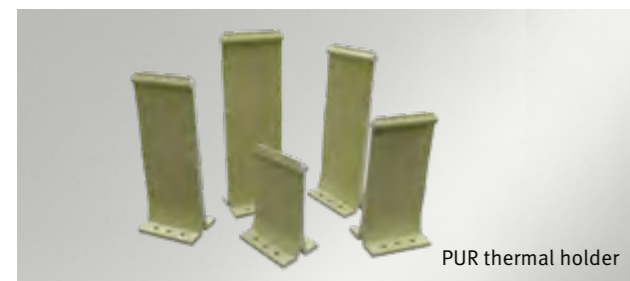



BEMO CORRUGATED PROFILES – BRINGING VERVE TO FAÇADE DESIGN



The classic in façade design is the corrugated profile. Corrugated profiles are an attractive and sustainable façade solution particularly in residential buildings, but also in industrial and commercial buildings. When combined with the numerous options for colours, surfaces and materials, they give your building a special touch.

EXECUTED IN HIGH-QUALITY ALUMINIUM OR ECONOMICAL STEEL – CORRUGATED PROFILES ALWAYS ENSURE AN INTERESTING ARCHITECTURAL AMBIENCE IN THE DESIGN OF THE FAÇADE.

You can select from four different sine waves, depending on the size of the façade area. Each profile can therefore be used horizontally or vertically. Back-ventilated curtain façades are preferably assembled on the thermal bridge-free TEKOFIX substructure. Also as covering for cassette systems in industrial and commercial buildings. An extensive range of system accessories rounds off our offer of corrugated profiles.

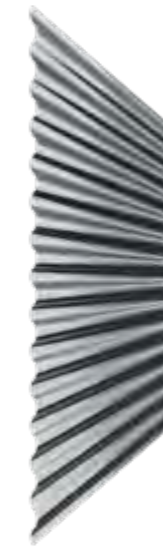

WP 18-76

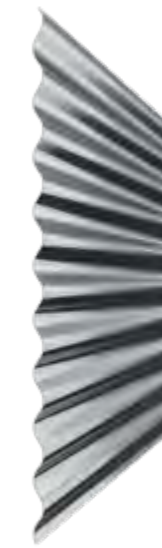

WP 27-111

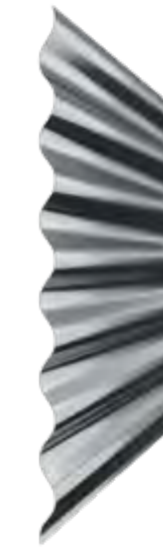

WP 42-160

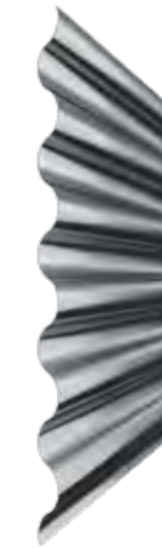

WP 55-177

**CORRUGATED PROFILES –
THE CLASSIC METAL FAÇADE**



OVERVIEW OF BEMO CORRUGATED PROFILES



THE NUMEROUS BENEFITS:

- ❖ Full BEMO colour variety also available for our corrugated profiles.
- ❖ In all metals, e.g. aluminium, steel, stainless steel, zinc or copper.
- ❖ Selectable surfaces: e.g. natural finish or brushed, painted or stuccoed.
- ❖ All flashings and connectors from the same primary material.
- ❖ Lengths up to 17.50 metres.
- ❖ Perforated models with perforation up to 40 %.
- ❖ Can be laid horizontally, vertically or diagonally.
- ❖ Thermal bridge-free assembly on the TEKOFIX substructure.

The BEMO technical team supports you with planning, tendering and dimensioning on-site.

Corrugated profiles

		WP 18-76 / WP 27-111	WP 42-160 / WP 55-177
Material thickness in mm	Steel	0.63 – 0.88	0.75 – 0.88
	Aluminium	0.7 – 1.00	0.9 – 1.00
	Aluzinc	0.63 – 0.88	0.75 – 0.88
	Stainless steel	0.7	0.7
	Copper	0.7 – 1.00	0.7 – 1.00
	Titanium zinc	0.8 – 1.00	on request
Coatings	PE / PVDF / BEMO-DUR / ML / BEMO-FLON		
Surfaces	Stucco / brushed / Aluzinc / pre-weathered / cladded		
Max. length	Depending on material; 17.50 m		
Perforation patterns	Rv 3.00 – 5.00	Rv 5.00 – 8.00	
Material	Aluminium		
Material thickness in mm	0.9-1.0		

Test report on structural type testing for corrugated steel profiles, test report No. T14-181 DIBt No. Z-14.1-548 for aluminium corrugated profiles and their connections

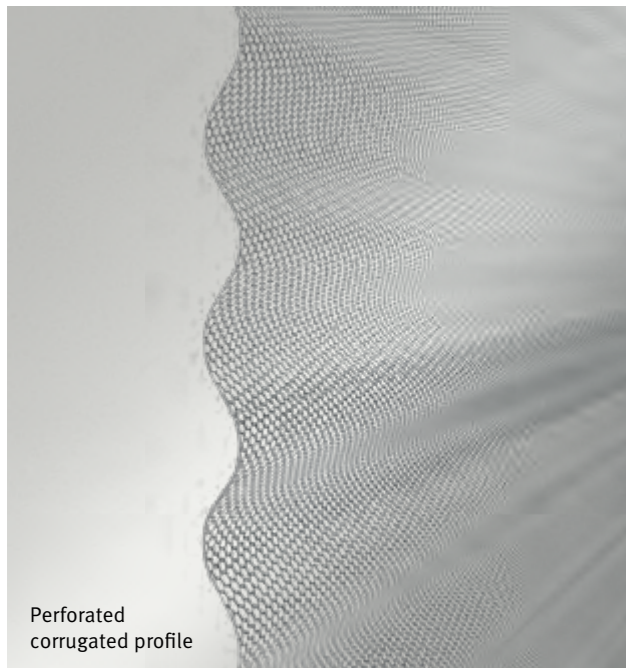

Perforated corrugated profile

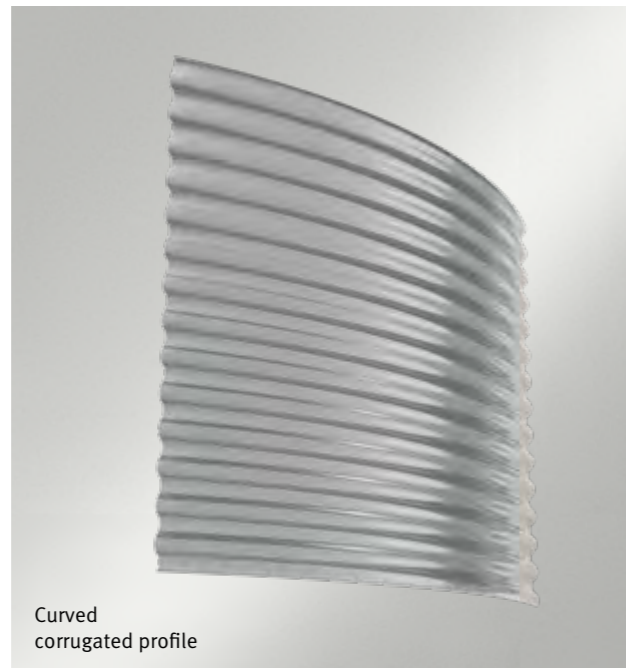

Curved corrugated profile

TRAPEZOIDAL PROFILES – THE ECONOMICAL SOLUTION

BEMO TRAPEZOIDAL PROFILES – THE COST-EFFECTIVE FAÇADE SOLUTION OFFERING GREAT VARIETY

THE BEMO TRAPEZOIDAL PROFILE PROVIDES THE MOST COST-EFFECTIVE SOLUTION FOR FAÇADES. IN ALL BEMO COLOURS – WITH ALL BEMO SURFACES AND MATERIALS.

Depending on the profile geometry, they can have wide clearances between the required fastening points, thereby reducing the work involved on the substructure.

Design variants are provided by the various profile geometries. Evenly profiled geometries appear harmonious from a distance – unevenly profiled geometries highlight the appearance of the surface. BEMO trapezoidal profiles are suitable for covering cassette systems, for direct assembly on the substructure of unheated buildings or as a covering for back-ventilated curtain façades.

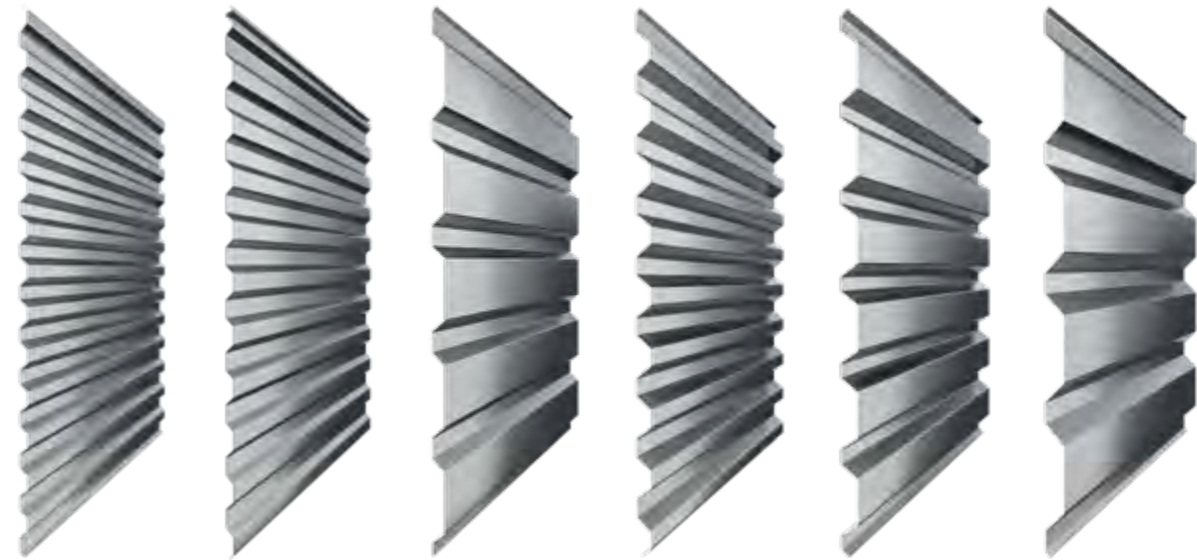

TP 20-75

TP 20-100

TP 35-207

TP 40-100

TP 45-150

TP 50-250



OVERVIEW OF BEMO TRAPEZOIDAL PROFILES



THE NUMEROUS BENEFITS:

- ❖ Full BEMO colour variety also available for our trapezoidal profiles.
- ❖ In all metals, e.g. aluminium, steel, stainless steel, zinc or copper.
- ❖ Selectable surfaces: e.g. natural finish or brushed, painted or stuccoed.
- ❖ All flashings and connectors from the same primary material.
- ❖ Lengths up to 19.50 metres.
- ❖ Perforated models.
- ❖ Can be laid horizontally, vertically or diagonally.
- ❖ Thermal bridge-free assembly on the TEKOFIX substructure, as profile for unheated buildings, or as a covering for cassette systems.

The BEMO technical team supports you with planning, tendering and dimensioning on-site.

Trapezoidal profiles

TP 20-75 / TP 20-100 / TP 35-207 / TP 40-100 / TP 45-150 / TP 50-250		
Material thickness in mm	Steel	0.50 – 0.88 (depending on the profile)
	Aluminium	0.50 – 1.00 (depending on the profile)
	Aluzinc	0.50 – 0.88 (depending on the profile)
	Stainless steel	0.70 (not TP 20-75 or TP 20-100)
	Copper	0.70 – 1.00 (not TP 20-100)
Coatings	PE / PVDF / ML / BEMO-FLON	
Surfaces	Stucco / brushed / Aluzinc / pre-weathered / cladded	
Max. length	Depending on material and profile; up to 19.50 m	
Perforation patterns	Rv 3.00 – 5.00	Rv 5.00 – 8.00
Material	Aluminium	
Material thickness in mm	0.9-1.0	

Test report on structural type testing for steel trapezoidal profiles, test report No. T14-159, test report on the structural type testing for aluminium trapezoidal profiles, test report No. T14-188

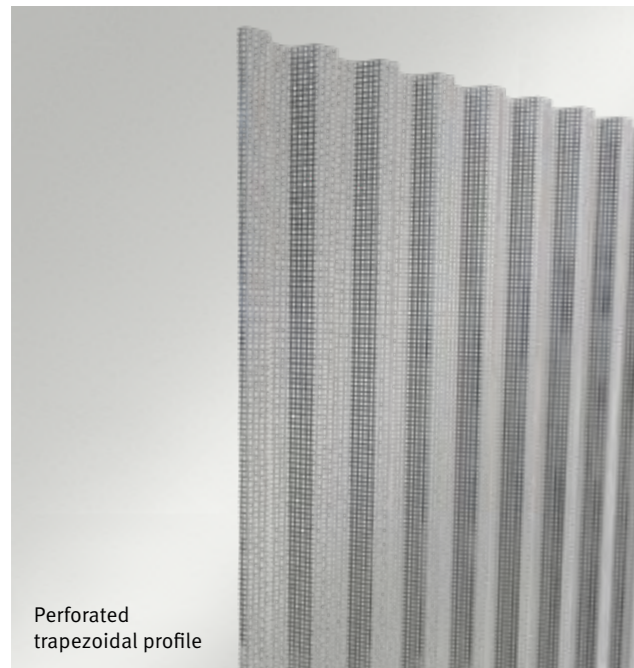

Perforated trapezoidal profile

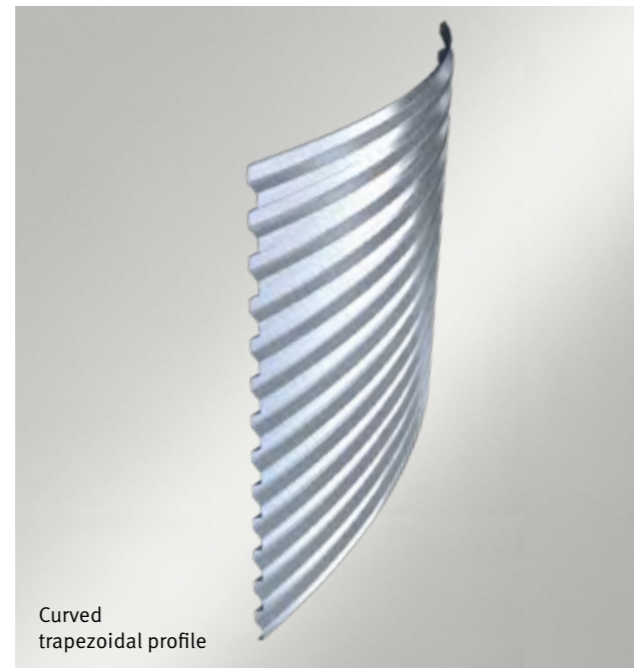

Curved trapezoidal profile



COLOURS

METALLIC					NATURAL		
	Anthracite metallic	Silver metallic	Grey metallic	Manganese metallic		Sandstone metallic	Red Terra metallic
			ELEGANT				
	Naturalgreen metallic	Bronze metallic (504)		Ink Black (326)	Smoke Silver (501)	Grey metallic (502)	Champagne Silver (503)
				INTENSE			
	Deep Grey metallic (505)	Charcoal (551)	Sunrise Silver (600)		Intense Red 75	Intense Yellow 75	Intense Orange 75
			STANDARD RAL COLOURS				
	Intense Blue 75	Intense Green 75		Ruby Red 15	Light Grey	Cream White	Traffic White

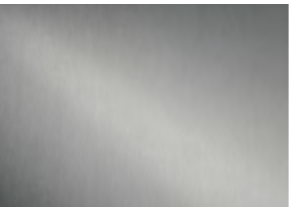
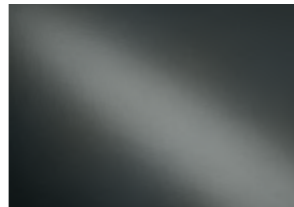
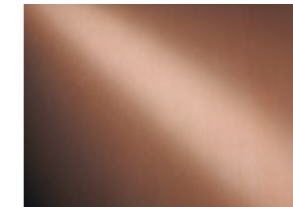

The colours shown are not binding, the shapes may differ from the original colours on our metal profiles.

AN ENDLESS VARIETY OF DESIGN OPTIONS – WITH BEMO

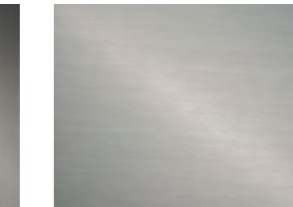

METALS

				
Aluminium	Steel	Copper	Stainless steel	Titanium zinc

SURFACES

				
Stucco	Brushed	Aluzinc	Anodized	BEMO-FLON®

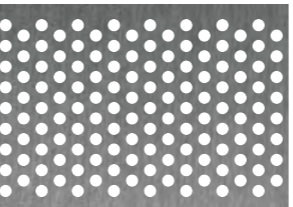
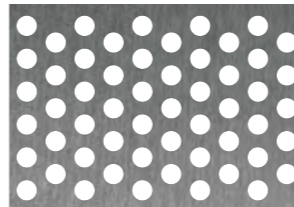
PERFORATION PATTERNS

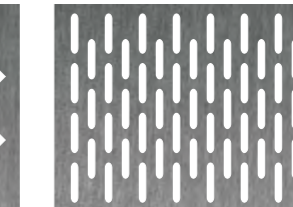
				
Rv 3-5	Rv 5-8	SW 11-14	Qd 7,5-11,5	Lg 1x20-2,5x24



Wei-Wu-Ying Center Kaohsiung // Taiwan
 Architect: Mecanoo Architecten, Delft
 Photo: provided by CK group



Convention Center, Lausanne // Switzerland
 Architect: Richter Dahl Rocha & Associés architectes
 Photo: Sérgio Guerra



Central Station Salzburg // Austria
 Architect: kadawittfeldarchitektur, Max Schöneich
 Photo: ©pierer.net

BEMO IS YOUR PARTNER FOR EXCELLENCE IN ARCHITECTURE – FOR FAÇADES AND ROOFS



BEMO has a unique range of services for metal roofs of all sizes, for every roof shape and for every climate zone. Naturally in the unique variety of materials and colours that you already know from BEMO façades.

BEMO is the indisputable global leader in technology for complex metal-roof projects. Due to our patented production technology and incomparable 3D planning instruments, we always and everywhere deliver the highest quality “Made in Germany”. Using materials of the highest quality, thorough planning and low-wear assembly systems, BEMO ensures the long-life of the cladding materials. We are able to directly produce our roof profiles anywhere in the world using our mobile production machines.

BEMO has the knowledge and technology to implement your ideas. Visions become reality.

Storage building // Germany
 Architect: Schmelzle + Partner GmbH
 Photo: Ulrich Marx / vor-ort-foto.de



THE SKY'S THE LIMIT

DESIGN AND VARIETY

BEMO specialises in projects whose implementation initially seems impossible. The award-winning, patented BEMO-MONRO system allows a design language that could not be implemented for a long time previously. A revolution for the design of roofs and façades in freeform architecture.

We create an interesting architectural ambience with innovative surfaces and materials. Our colour coatings are in all conceivable shades – and in all gloss grades. The variable design of the tracks ensures optimal fidelity to the track on every building. We provide a limitless variety in the implementation of your ideas.

ECONOMY

Appealing building design must not only meet the highest aesthetic demands. Economic feasibility and cost-efficiency also play a decisive role.

Thanks to our mobile production technology, we can produce on site, thus reducing the number of material transports required. As well as quality, in our material range we place the emphasis on durability and maintenance costs, e.g. surfaces with very long cleaning intervals.

3D measurement of the substructure detects tolerances and prepares the material for simple and safe assembly. This means cost efficiency, from planning through to building maintenance.

SUSTAINABILITY

We expend a lot of energy to make sure that a building needs as little of it as possible. The best method is the use of innovative systems.

The BEMO GFK thermal holder is free of highly heat-conductive components and thereby aids in a thermal bridge-free roof construction. Using our system-compliant mounting rails, we achieve completely non-penetrative surfaces for the use of solar modules within photovoltaics and solar heating.

The aluminium we use has an exceptional ecological balance. It is up to 100 percent recyclable.

QUALITY AND PERFECTION

We only use quality material from renowned suppliers. The multitude of available materials, surfaces and colours can be combined optimally. Our 3D planning and flexible substructure systems provide a secure basis for our BEMO-MONRO freeform system. Our patented production machines are mobile and so available everywhere. Our File-to-Factory software ensures perfect implementation of planning during production.

You can rely on a perfect implementation of your project in excellent quality – completely.

INDIVIDUALITY

We support the courage of unusual approaches and distinctive architecture. Variable widths of standing seam tracks and lengths of over 100 metres are both flexible and secure. Concave and convex arches down to the smallest radii can be achieved, and the tracks can always be adjusted to run along the required building shape. BEMO-MONRO allows for implementation of freeform and double-curved structures with one metal roofing – without any loss in quality of the appearance.

The combination of BEMO materials, surfaces and colours provides innumerable design possibilities. To create freedom for individuality of all kinds.

INTERNATIONALITY

BEMO is a global brand comprised of several strong, independent companies.

With branches and partners in Europe, North- and South America, the Middle East and Singapore, we are represented globally with seven production locations and numerous mobile production lines. An international network of first-class installation companies helps us and our customers in the implementation of top-quality projects – irrespective of the geographical location.

Our sales and technology team is multilingual and experienced in global projects with the most varied requirements. Wherever you are implementing your project: we are on site!



WWW.BEMO.COM

BEMO SYSTEMS GmbH

Max-Eyth-Straße 2
74532 Ilshofen-Eckartshausen
Germany

T: +49 7904 29899-60
F: +49 7904 29899-61
E: sales@bemo.com
W: www.bemo.com

BEMO Project Engineering UK Ltd.

Jessop House, Outrams Wharf,
Little Eaton,
Derbyshire, DE21 5EL,
United Kingdom

T: +44 1773 853 694
E: sales@bemouk.com
W: www.bemo.com/en-uk

BEMO Dış Cephe Çatı Kaplama

Sistemleri Ticaret ve Sanayi Ltd.Sti
Göktürk Cad. Suvenue Sitesi C Blok
Daire 7, Göktürk, 34077
İstanbul – Türkiye

T: +90 2123 227 472
F: +90 2123 227 574
E: pazarlama@bemo.com
W: www.bemo.com

BEMO SYSTEMS GmbH

Via Serbelloni 47
20064 Gorgonzola (MI)
Italy

T: +39 02 365 420 81
E: servizio@bemo.com
W: www.bemo.com

BEMO SYSTEMS GmbH

Volgogradsky Av. 43 bld. 3
office 166
109316, Moscow
Russian Federation

T: +7917 508 78 30
E: sales.russia@bemo.com
W: www.bemo.com