

BEMMO



ROOF

SHAIRES



METAL ROOFS





THE SKY'S

THE LIMIT

**AT BEMO THERE'S ONLY ONE THING WE TELL YOU –
FORGET EVERYTHING YOU'VE BEEN TOLD!**

Follow your own style. We give architects and planners the freedom to ignore conventions. Based on decades of experience with complex building shapes, high design and technical standards and the numerous unique projects we have completed around the globe, we are confident in saying: "Impossible is not a word you will hear at BEMO." Our technical planning department, recognised as one of the leading computational design teams worldwide, collaborates with architects and planners to deliver the perfect solution to implement your ideas, totally in harmony with our motto "The sky's the limit". Metal roofs and façades from BEMO are durable, low maintenance and are very economical. They comply with the highest technical requirements and standards of building physics. With our patented production processes we are capable of transforming metal surfaces into an endless variety of shapes. The materials we use are recyclable. BEMO is the ideal partner for your building project worldwide.

Design

DESIGN AND AESTHETICS ARE PART OF BEMO.



Wei-Wu-Ying Center Kaohsiung // Taiwan
Architecture: Mecanoo Architecten, Delft
Photo: provided by CK group

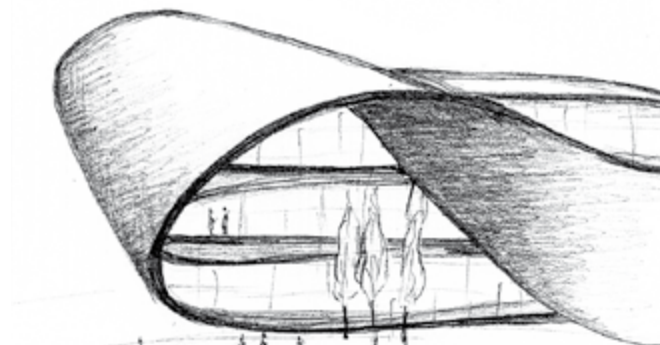

THINK FREELY, DESIGN FREELY, PLAN FREELY.

Architecture which causes a sensation always bears an individual signature. It is the foundation for the success of a concept. We make your design ideas a reality. Together we can find ways and solutions to create spectacular roof shapes. We allow the play of light and shade, bring colours to life according to the time of day and integrate surfaces which withstand any climate.



Sports hall Campus Trivaux Garenne // France
Architecture: Gaëtan Le Penhuel & Associés Architectes, Gaëtan Morales
Photo: Sergio Grazia



Convention Center Astana // Kazakhstan
Architecture: Adrian Smith + Gordon Gill, Chicago

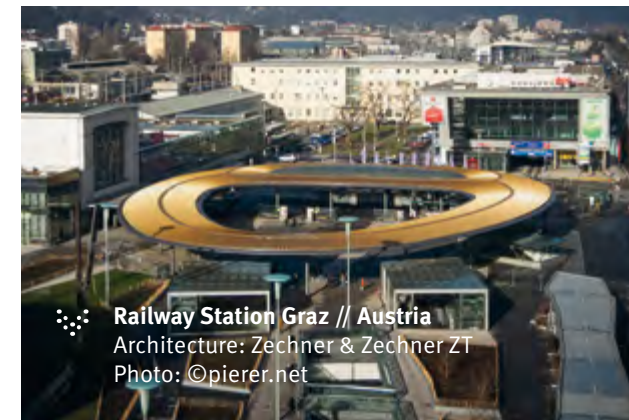

Railway Station Graz // Austria
Architecture: Zechner & Zechner ZT
Photo: ©pierer.net

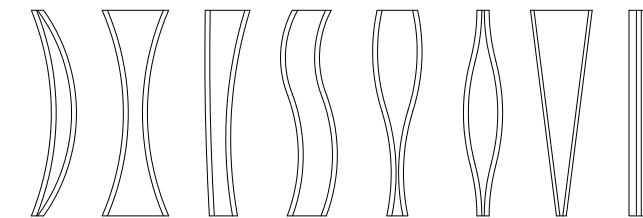

FREEFORM METAL PROCESSING. CUT IN INDIVIDUAL SHAPES. AVAILABLE IN VARIABLE WIDTHS. ALSO IN EXCESS LENGTHS. THAT IS WHAT BEMO STANDS FOR.



Airport Zagreb // Croatia
Architecture: IGH d.d. & Neidhardt arhitekti d.o.o. & Kincl d.o.o.
Photo: MZLZ/Josip Skof

COLOURS, SHAPES AND SURFACES – FREELY SELECTABLE.

We can process a wide variety of easily formed and cost effective metals. This includes “living” materials such as aluminium, zinc or copper with a natural finish and chemically resistant stainless steel. Metals can also be colour coated using premium quality coating systems, offering incomparable variety in design.

Variety

DESIGN AND VARIETY



Quality

GERMAN ENGINEERING – VALUED AROUND THE GLOBE.

We work according to international standards for planning, production and product quality. We also comply with all important European and international regulations. If necessary, we can transport our mobile production machines to site. Our highly qualified staff are involved in your project during every phase and are happy to assist you with quality control.



GERMAN ENGINEERING



 Waterworld, Langenhagen // Germany
Photo: Claus Kirsch/vor-ort-foto.de

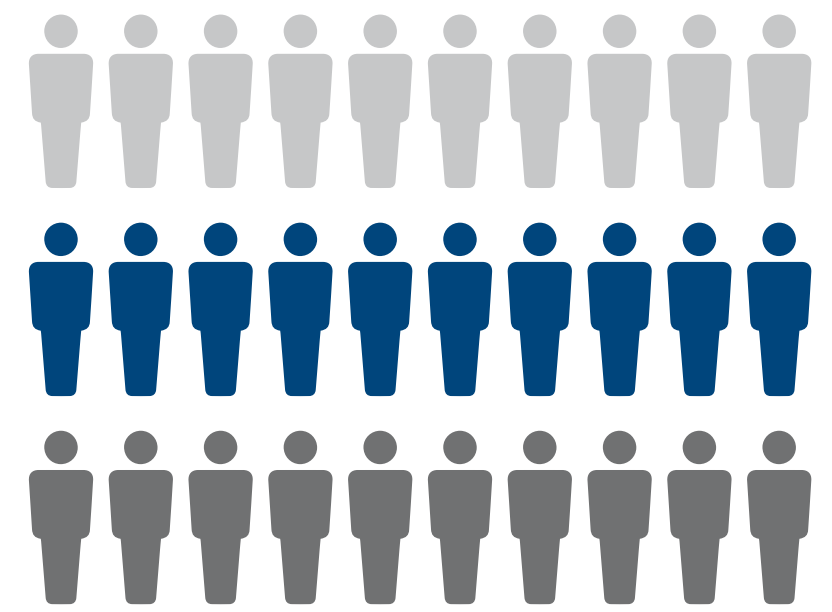

BEMO HAS ONE OF THE LARGEST 3D PLANNING OFFICES FOR METAL ROOFS IN THE WORLD. OUR TEAM SPEAKS SEVERAL LANGUAGES.

ALL-ROUND SUPPORT – IN EVERY PHASE OF YOUR PROJECT.

Not all service standards are the same. You can rely on BEMO services throughout the whole project. We are there for you, starting with the design phase and, if you so wish, we will take responsibility for the detailed design and material logistics for the whole roof and façade package.

Services

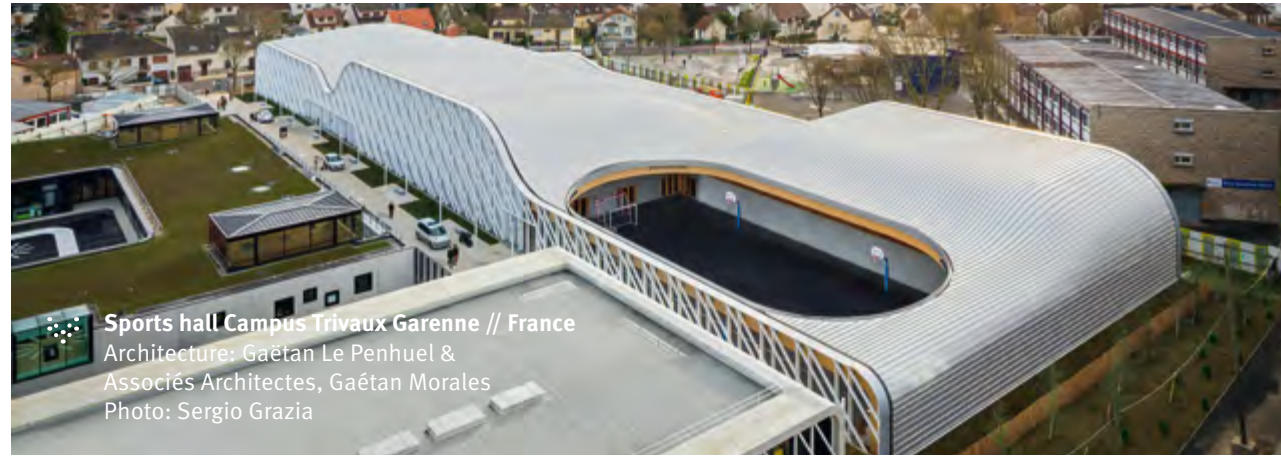

Sports hall Campus Trivaux Garenne // France
Architecture: Gaëtan Le Penhuel & Associés Architectes, Gaëtan Morales
Photo: Sergio Grazia

WE SUPERVISE
PROJECTS FOR OUR
CLIENTS AROUND
THE GLOBE.



Glasgow Hockey Centre // Scotland
Architecture: Glasgow City Council

ROOFS MAKING THEIR MARK.

Hundreds of projects in all climate zones are proof of the capabilities of BEMO's international organisation. Clients' demands on us are often challenging – encountering ice and snow, sand and heat, environmental pollution and sustainability. Other challenges are desert and subtropical climates, projects in permafrost zones or being by the sea – BEMO's experience along with tried and tested products are in great demand everywhere. Millions of square meters of roofed areas are proof.



Experience

Worldwide



Railway Station Astana // Kazakhstan
Architecture: Tabanlıoğlu Architects
Photo: © Emre Dörter



Wei-Wu-Ying Center Kaohsiung // Taiwan
Architecture: Mecanoo Architecten, Delft
Photo: provided by CK group

WE ARE THERE FOR YOU – EVERYWHERE.

We are a high-performance company and a global brand; with offices in Europe, the USA and Asia, BEMO has an international network of top-class installation companies. Wherever you want to implement your project: BEMO quality is available to you - everywhere. Our systems have been tested according to all international standards and requirements.

12

STANDING SEAM

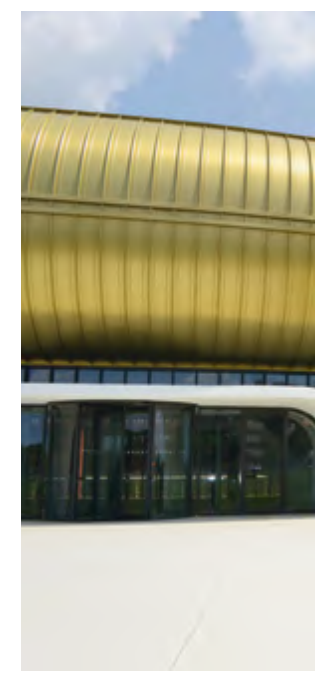

22

MOBILE PRODUCTION ON SITE

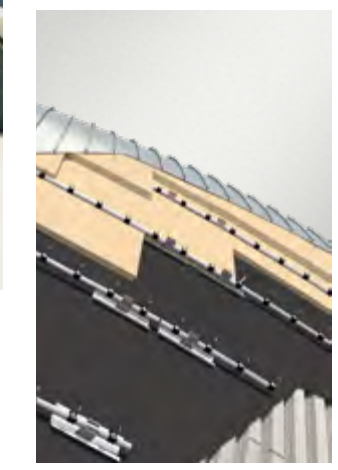

28

BEMO-DOME SUBSTRUCTURE



30

RESTORATION SYSTEMS

24

HALTERS AND FASTENINGS



26

SUBSTRUCTURE

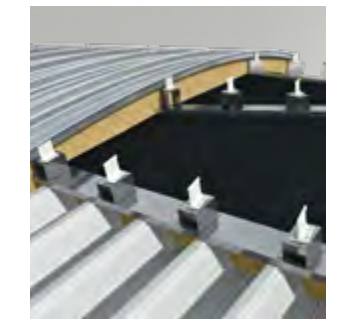

BEMO – YOUR SUPPLY CHAIN PARTNER

32

ENGINEERING

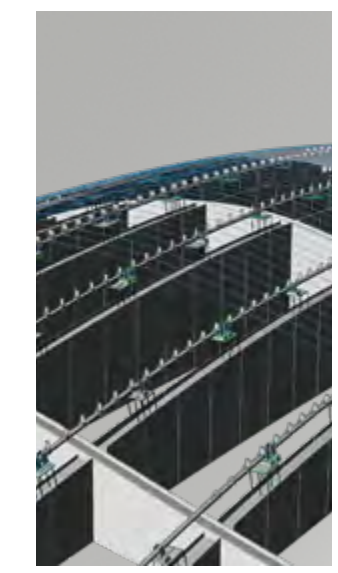

34

BEMO ROOF STRUCTURES

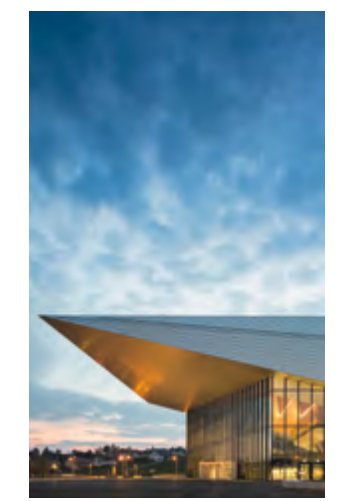

44

RAINSCREEN / PHOTOVOLTAICS

42

STRUCTURAL ANALYSIS AND BUILDING PHYSICS

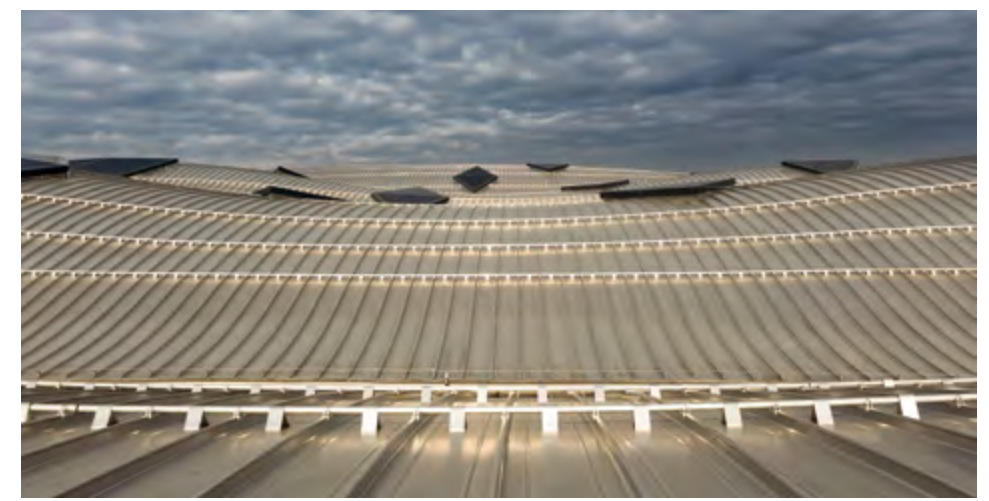
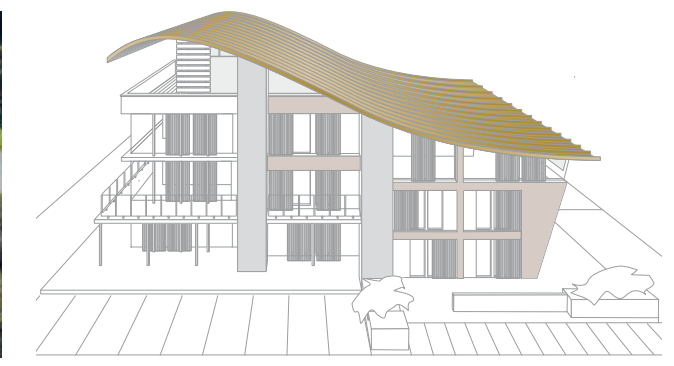

46

ON-ROOF SYSTEMS



Museum, Prato // Italy
Architecture: NQ architects



BEMO'S METAL ROOFING SYSTEM – EXCEPTIONALLY VERSATILE



There is scarcely another roof system which satisfies so many requirements as a multilayer roof system with standing seam profiles.

The profiles are self-supporting and do not need to be installed using screws which penetrate the roof surface. Variable sheet lengths are available exceeding 100m in length if required and avoid transverse overlaps in the roof, thus reducing the risk of leaks. Connections, for example to light domes, are welded to make permanent joints. Aluminium, the material used, conserves resources since it is sourced primarily from recycled material which can be recycled again for decades to come.

Aluminium is highly resistant to corrosion and weathering, but offers high formability and easy malleability. It is this formability, in combination with BEMO's unique production technology, which makes the BEMO system stand out with adaptability of the metal covering to almost any building geometry.

IT SATISFIES ALL TECHNICAL REQUIREMENTS,
OFFERS VERY LONG SERVICE LIFE AND IS
LOW-MAINTENANCE.

Roof structures offer a variety of options - and always match the needs to be satisfied by the building. They also offer very good thermal transmission values up to $<0.15 \text{ W}/(\text{m}^2\text{K})$. Double-layer metal roofs, such as the BEMO system, are ideal for stringent soundproofing requirements and are almost unparalleled. With our special roof structures we can achieve sound protection values of $>50\text{dB}$.

Roof renovations or complex structures are frequently characterised by significant building tolerances which can be compensated for optimally by one of the BEMO substructure systems. The variety of choice in surfaces, materials and colours offers maximum flexibility and freedom in design.

FACT SHEET

- LONG LIFE
- UP TO $<0.15 \text{ W}/(\text{M}^2\text{K})$
- LOW MAINTENANCE
- UP TO $>50\text{DB}$ SOUND PROTECTION
- FREEFORM DESIGN

Sports hall Campus Trivaux Garenne // France
 Architecture: Gaëtan Le Penhuel & Associés Architectes, Gaëtan Morales
 Photo: Sergio Grazia



BEMO STANDING SEAM – PERFECTION MATCHED WITH MAXIMUM SAFETY

STANDING SEAM PROFILES – CURVED, MULTI-DIMENSIONAL AND FREEFORM

Some architects and owners have rather challenging demands - and this matches perfectly with BEMO standing seam products. Freeform, flowing transitions from the roof to the façade, functionally necessary or architecturally desirable cylindrical and 3D-dimensional building shapes, or very long individual tracks for maximum safety on roofs with a slight incline. Independent test and approvals, e.g. DIBT in Germany, BBA in England or FM Global in America, certify the quality and function of the system. BEMO standing seam products satisfy every requirement and are available in the following options:

- Available materials: aluminium, steel, stainless steel, copper, titanium zinc,
- Surfaces: coated, natural, natural stuccoed, brushed, anodised
- Colour systems: BEMO-FLON, PVDF, HDP, polyester, ARS
- Colours: according to the customer's wishes

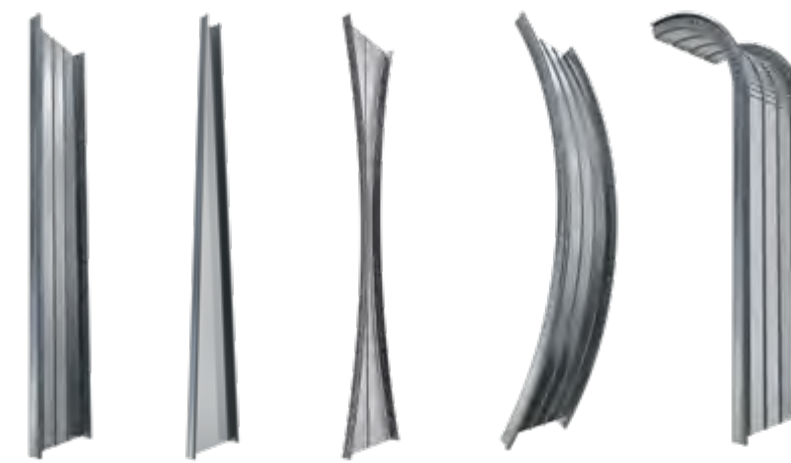

straight tapered freeform BEMO-MONRO curved crimp curved

FACT SHEET

- RECYCLABLE
- FREEFORM
- WIDE RANGE OF MATERIALS AND COLOURS TO CHOOSE FROM
- CAN BE ADAPTED TO ANY SHAPE OF BUILDING
- INTERNATIONALLY CERTIFIED



Indoor swimming pool // Luxembourg
Architecture: 4a Architekten GmbH



Company building, Gammertingen // Germany
Photo: SkyImage.de/vor-ort-foto.de

BEMO STANDING SEAM – STRAIGHT PROFILES

THE 3 PROVEN AND TESTED PROFILE OPTIONS ARE AVAILABLE FOR ALL MATERIALS:

N 65 – with a base height of 65mm and variable profile widths. Because of the high base height the profile is especially well suited to roofs with a low pitch. It also offers very good load bearing capacity hence good structural values.

N 50 – with a base height of 50mm and variable profile widths. It has a subtle and aesthetic appearance and is, therefore, also used on smaller roof areas such as single-pitch roofs of residential buildings.

VF 65 – with a base height of 65mm and variable profile widths. The profile lies fully flush when installed on rigid insulation and roof boarding. A special mould holds the holding base in place and does not leave any marks. This profile is often used to renovate old roofs.

The number and position of the stabilising centre beads is variable and can be individually defined as a design element.

The BEMO standing seam profiles are available in special designs:

- ❖ with fleece to protect against condensation water
- ❖ with a sound-proofing layer to deaden the sound of rain
- ❖ perforated as shading elements in the façade

Lengths of considerably more than 100 metres are feasible for on-site production.

BEMO STANDING SEAM

Profile	N50	N65	VF65		
Cover widths	333 mm, 429 mm, 529 mm, 600 mm	305 mm, 333 mm, 400 mm, 500 mm, 600 mm	305 mm, 333 mm, 400 mm, 434 mm, 500 mm, 600 mm		
Variable widths	from 100 mm	from 100 mm	120 mm – 800 mm		
Materials	Aluminium	Steel	Stainless steel	Copper	Titanium zinc
Thickness mm	0.8 – 1.2	0.63 – 0.75	0.6 – 1.0	0.8 – 1.0	0.7 – 1.0

Coating Systems: BEMO-FLON / PVDF / Polyester

Surfaces: Stucco / brushed / Aluzinc / pre-weathered / cladded

Production: factory production < 38 m, one-site production > 38 m

Perforations	Rv 3.00 – 5.00	Rv 3.5 – 5.00	Rv 5.00 – 8.00	SW 11-14	no perforations
Material	Aluminium				
Thickness mm	1.0 – 1.2				

Building authority approvals:
Z-14.1-182 BEMO-FLAT-ROOF aluminium standig seam profile roof elements
Z-14.1-640 BEMO-FLAT-ROOF standig seam profile roof elements in steel
also available: FM approvals, ASTM, BBA certificate, Avis Technique, GOST





Indoor swimming pool // Germany
Architecture: Fritz Planung



Digestion Tower // Austria
Architecture: Machowetz & Partner Consulting

BEMO STANDING SEAM – SPECIAL PROFILES

The patented BEMO-MONRO system stands for flexible adaptability of metal coverings to almost any building geometry. Each single track of a freeform building is often unique. The metal tracks are shaped in a single production step with millimetre precision on the basis of exact 3D measurements of the location where they will be installed on the building.

BEMO-MONRO® – FOR THE VERY HIGHEST DEMANDS OF SHAPE AND QUALITY

The MONRO system is normally used in combination with a 3-dimensional movable substructure. Unevenness in the supporting structure can be quickly and easily compensated. BEMO 3D planning - often based on a 3D scan of the supporting structure - plans the system to be ready for assembly.

Tapered, special profiles are used for large rotunda or cone-shaped buildings. A minimum width of 100 mm and a maximum covering width of 800 mm in a track mean almost any requirement can be implemented. The standing seam tracks are shaped in a single production step to fit exactly, avoiding laborious cutting to size on the project.

All BEMO SPECIAL PROFILES are also available in curved shapes and in all materials.

Profile	N50	N65	VF65		
Minimum width	100 mm	100 mm	200 mm		
Maximum width	800 mm	800 mm	800 mm		
Minimum length	3 000 mm				
Material	Aluminium	Steel	Stainless steel	Copper	Titanium zinc
Thickness mm	0.9–1.2	0.63–0.75	0.5–0.7	0.8–1.0	0.7–1.0
Production	factory production < 38 m, one-site production > 38 m				
Capillary groove	integrated into all panels				
Center ribs	parallel to the seams, straight centered or without				

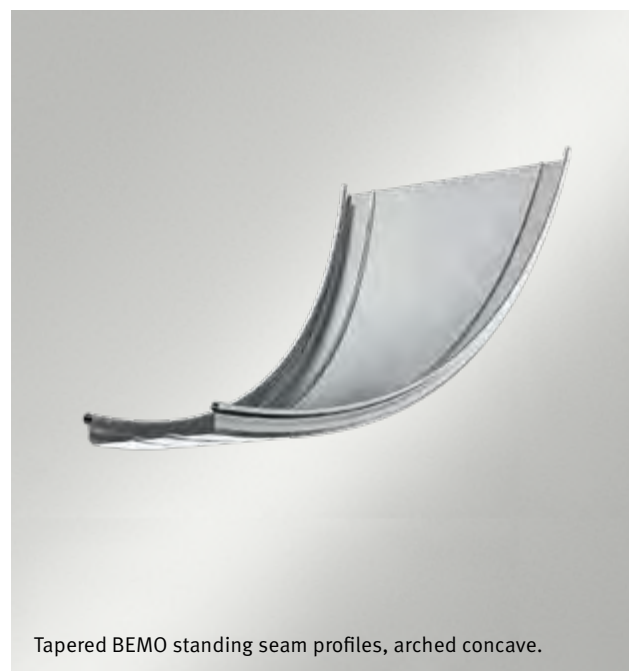

Tapered BEMO standing seam profiles, arched concave.



Tapered BEMO standing seam profiles, arched convex.

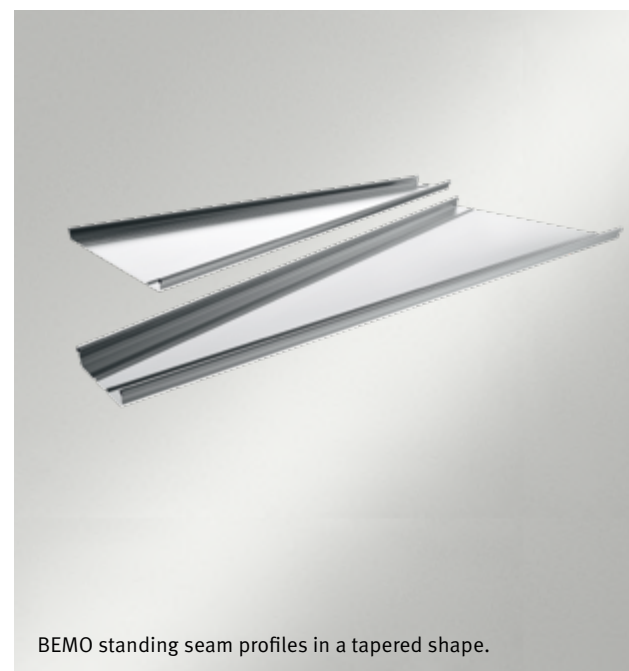

BEMO standing seam profiles in a tapered shape.



PSV sports hall Salzburg // Austria
Photo: Peter Heimpel / PH-foto.de



Sports hall Berlin // Germany
Architecture: Alten Architekten, Herr Dirk Alten
Photo: Klemens Ortmeier

BEMO STANDING SEAM – SPECIAL CURVED PROFILES



We create flowing building shapes with curved standing seam tracks.

A second production step, which is often used to optimise freight costs in combination with our mobile production facilities on site to ensure tracks fit exactly, transforms BEMO standing seam tracks into curved shapes.

A VARIETY OF SHAPES ADJUSTED TO THE INDIVIDUAL PROJECT AND PRODUCED ON SITE.

Curvatures can be concave, convex or concave-convex - down to the very smallest of radii. We can achieve minimum radii of less than 800 mm, depending on the material and profile selected.

All variations of BEMO profiles are suitable for subsequent curving. The functional reliability of the products is guaranteed even after curving.

To ensure assembly which can compensate for construction tolerances, we recommend using the BEMO substructure systems BEMO-DOME or BEMO-FLEX. 3D measurements of the shape of the building in its current state are recommended, as is our BEMO 3D implementation planning system.

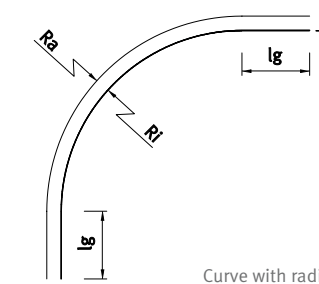

Convex curving	N50	N65	VF65	N50 tapered	N65 tapered	VF65 tapered	MONRO
t = 1,20 min Ri mm	800	800	2 000	3 000–5 000	3 000–5 000	3 000–5 000	2 500–3 000
t = 1,00 min Ri mm	1 000	1 000	2 500	3 000–5 000	3 000–5 000	3 000–5 000	3 000–5 000
t = 0,90 min Ri mm	1 200	1 200	3 000	–	–	–	–
Min leg mm	300	300	300	300	300	300	300

Concave curving	N50	N65	VF65	N50 tapered	N65 tapered	VF65 tapered	MONRO
t = 1,20 min Ri mm	5 000	5 000	12 000	16 000–18 000	16 000–18 000	16 000–18 000	10 000–12 000
t = 1,00 min Ri mm	5 000	5 000	14 000	16 000–18 000	16 000–18 000	16 000–18 000	12 000–14 000
t = 0,90 min Ri mm	10 000	10 000	17 000	–	–	–	–
Min leg mm	300	300	300	300	300	300	300

Crimp curving	N50	N65	VF65	N50 tapered	N65 tapered	VF65 tapered	MONRO
t = 1,0 – 1,2 min Ra mm	500	500	500	on demand			
Min leg mm	150	150	150	on demand			

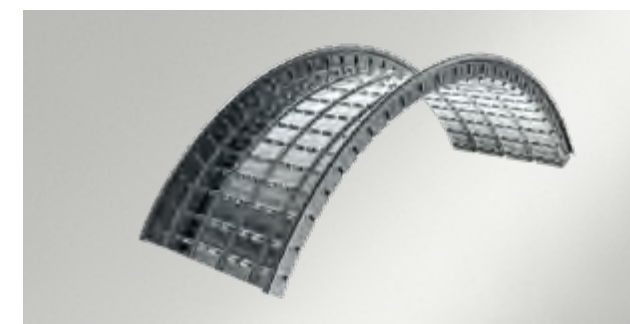
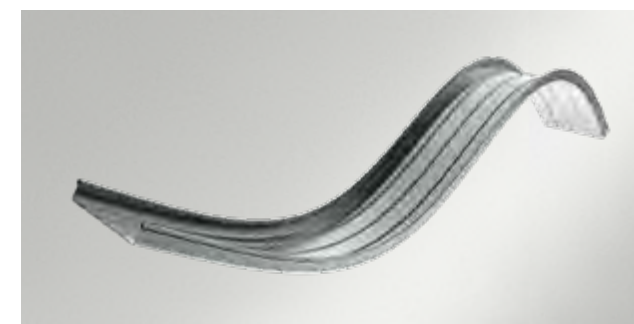
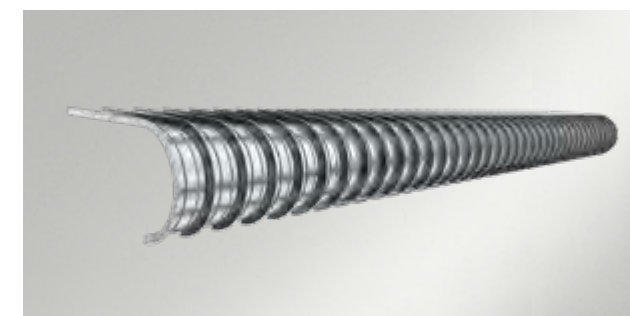
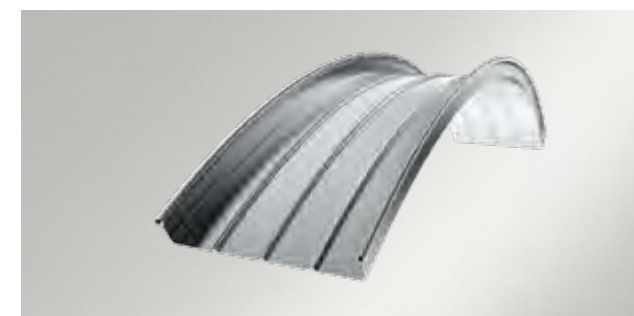



BEMO ROLL FORMER – GLOBALLY MOBILE

INNOVATIVE PRODUCTION TECHNOLOGY – MOBILE DEPLOYMENT AROUND THE GLOBE.

As a group of companies with strong German roots, BEMO has focussed on high-quality machines and state-of-the-art technology for decades.

“German Technology” is our promise to our international customers. Proof of this, for instance, is the patented BEMO-MONRO technology for producing freeform tracks in a single work step. Our latest curving machines catering for radii up to 800 mm – also in a single work step – set standards in the industry. All BEMO machines are mobile and can, therefore, be used directly on the construction site.

This reduces logistic expenses, conserves resources and ensures that precisely cut material is available at all times for assembly.

Very long track lengths in excess of 100m can be produced directly on site. This avoids transverse joints and weak points in the roof.

BEMO machines have proved their worth in all climate zones around the globe.



Video



Scan QR code and watch the assembly video

<https://www.youtube.com/watch?v=y6CBtFvBvpc&list=PLNai vOnK4ooHj9Rnxsdsu62LbfZWvaThq&index=0>



BEMO thermal halter

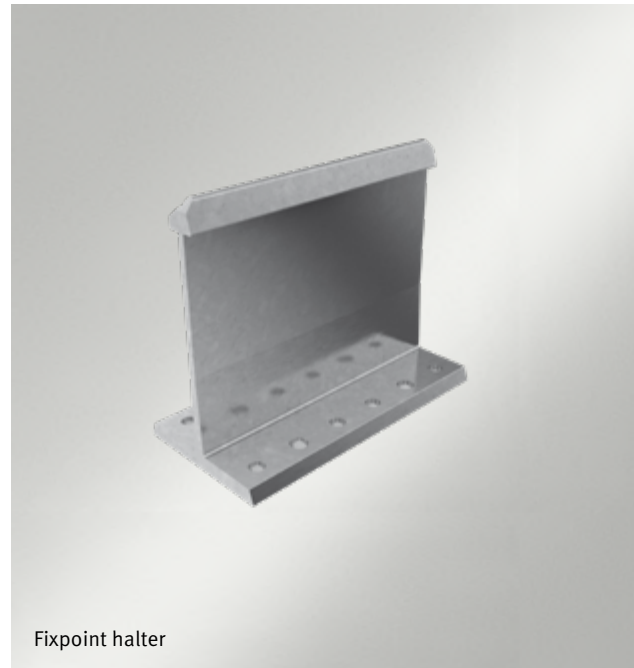

Fixpoint halter



BEMO HOOK halter

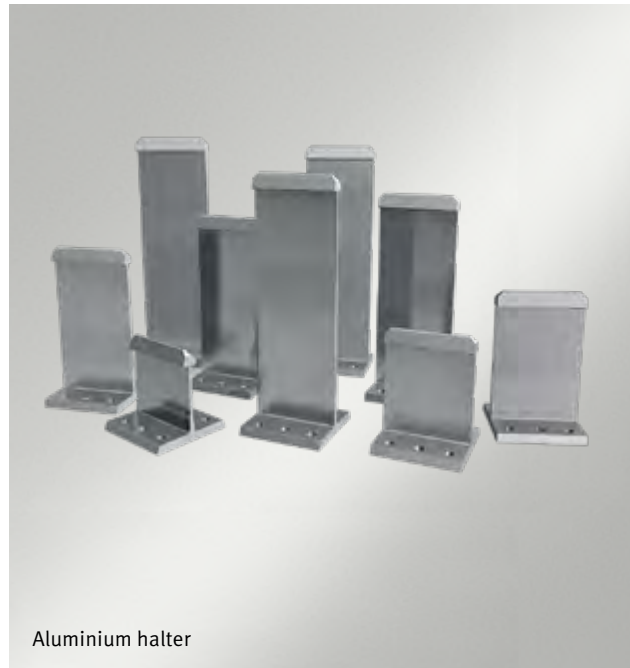

Aluminium halter

BEMO HALTER SYSTEMS – ALSO COMPLETELY THERMAL BRIDGE-FREE

ALUMINIUM HALTER:

The free sliding movement of the standing seam track during linear expansion caused by temperature changes is one of the most important features of a BEMO standing seam roof. With their rounded corners, BEMO aluminium halter have been designed especially for optimum sliding performance. The BEMO thermal barrier pads, TK 5 and TK 15, can be attached at the base of the halter to ensure thermal decoupling.

Bemo aluminium halter:

- ❖ High load-bearing capacity
- ❖ Good sliding movement of the standing seam tracks on the halter
- ❖ Thermal barrier pads ensure thermal decoupling

THERMAL HALTER:

Our halter made of fibreglass reinforced plastic are completely free of thermally conductive parts and therefore, are completely thermal bridge-free. As a result, the need for insulation material is reduced considerably. The halter are fire-tested and have passed all frost and damp tests. Their characteristic features have a high level of rigidity and very good load-bearing capacity.

Halter made of high-quality plastic

- ❖ High load-bearing capacity
- ❖ Very good sliding movement of the standing seam tracks
- ❖ Completely thermal bridge-free

BEMO HOOK HALTER FOR USE IN EXTREME WIND ZONES.

The HOOK halter is based on a completely new design principle. It overlaps the small standing seam flange and secures it permanently, especially from horizontal loads. Plain-bearing mounting of the standing seam profiles is at the holding base. The BEMO HOOK halter are therefore particularly suited to regions with high wind loads as well as zones with high ambient temperatures and consequent thermal expansion of the covering caps. The halter can be delivered with a galvanized or stainless steel base plate.

All BEMO halter systems are constructed and BBA tested and approved by building authorities in the relevant countries. We will be happy to develop the right fastening solution for you according to your project. We will recommend the correct type of halter, the recommended height of halter, the necessary intervals between halter and how to mount them correctly.

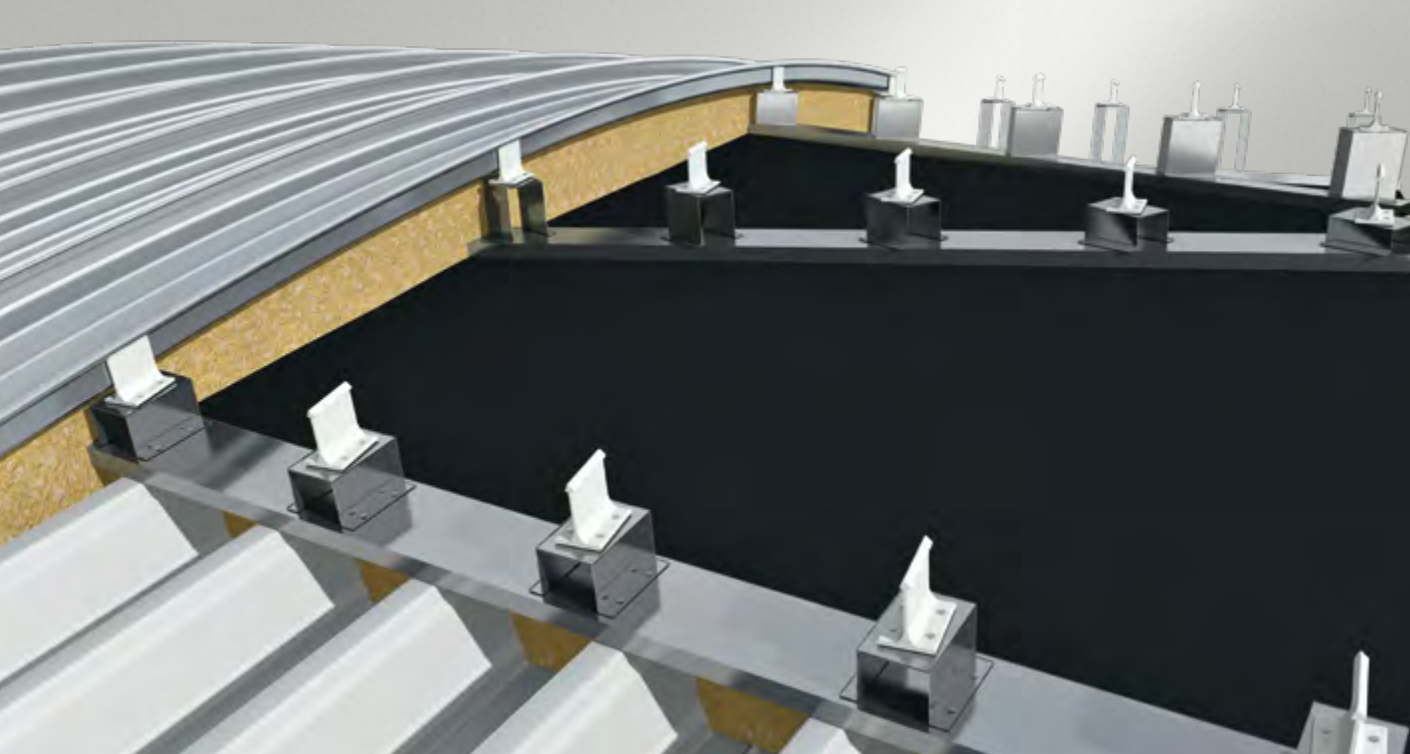

Ice Arena, Almaty // Kazakhstan

BEMO-FLEX – THE BASIS FOR A PERFECT BUILDING ENVELOPE – MAXIMUM FLEXIBILITY IN THE SUBSTRUCTURE



The patented BEMO-FLEX substructure ensures a precise fit and high quality execution of metal coverings, even on complex building shapes – and even when renovating old buildings with construction tolerances that are often high.

BEMO-FLEX is a segmented substructure. The system is extremely easy to assemble and allows you to design a 3D outer layer in easy work steps while compensating for all construction tolerances.

COST-EFFECTIVE WITH WORKSHOP PRE-ASSEMBLY OF THE WHOLE SUBSTRUCTURE SYSTEM.

The combination of a modern “Computational Design” planning method and measurement of the existing construction allows BEMO-FLEX to be used anywhere without problems.

The lower U profiles of the FLEX SYSTEM are mounted in accordance with structural requirements. The mounting position of the U profiles is recorded in a 3D scan. From this we derive the required position and height of each BEMO halter. The upper U-shaped rail is pre-assembled with the positioning brackets in the workshop and then screwed to the lower U-shaped rail in a second work step.

By adjusting the design of the substructure, very large tolerances can be compensated or new building envelope forms developed.

SO COMPLICATED BECOMES EASY!

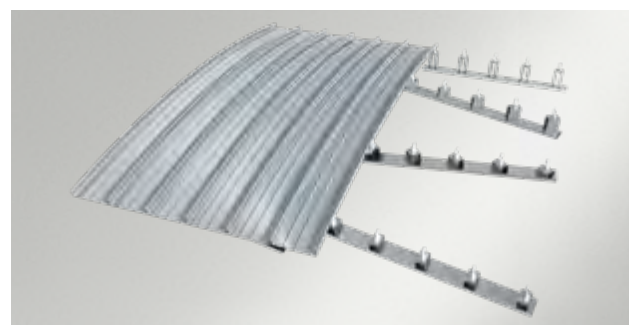
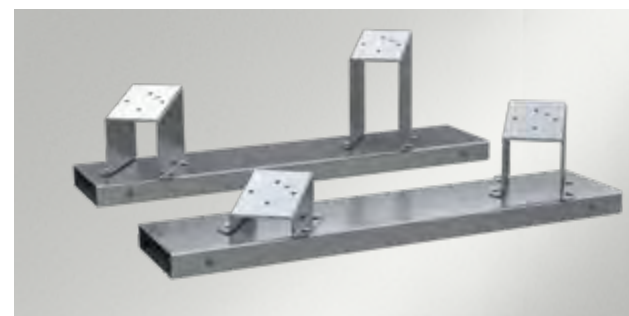
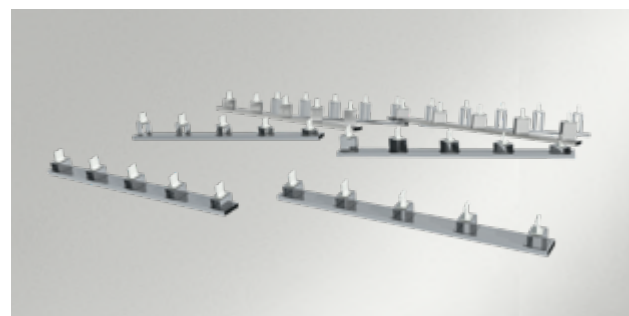

FACT SHEET

- HIGH LOAD-BEARING CAPACITY OF THE SYSTEM
- HIGH PRECISION THROUGH 3D MEASUREMENTS AND PLANNING
- COST-EFFECTIVE PRODUCTION IN THE WORKSHOP
- VERY EASY ASSEMBLY

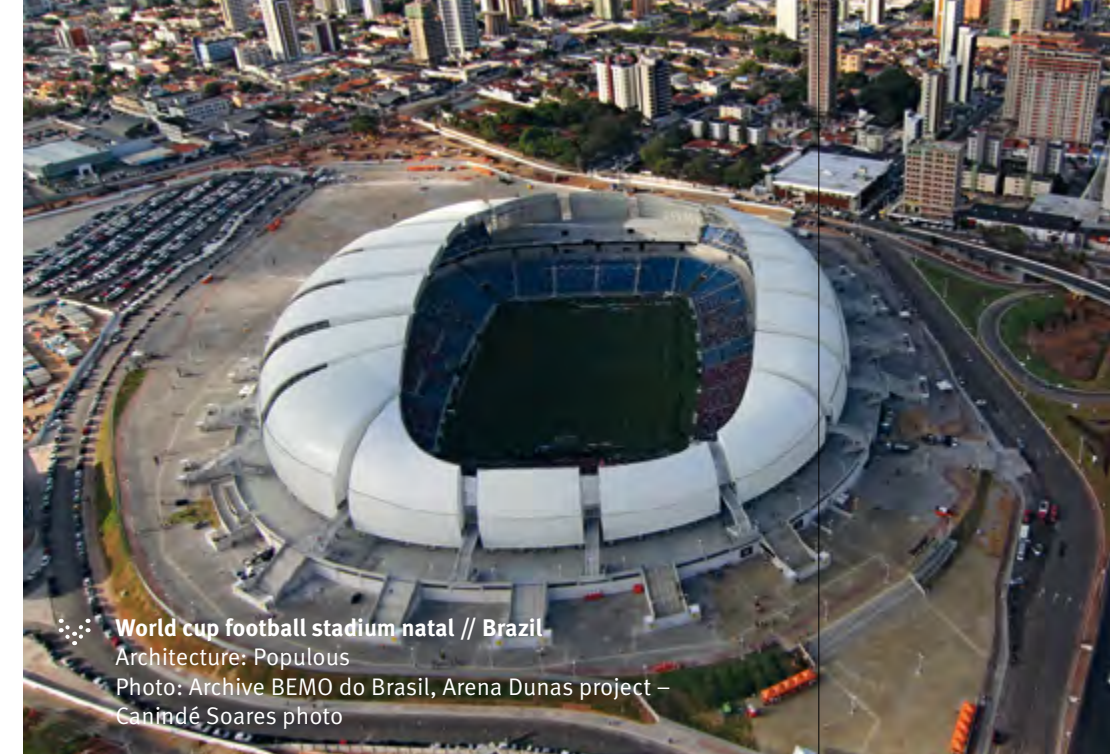
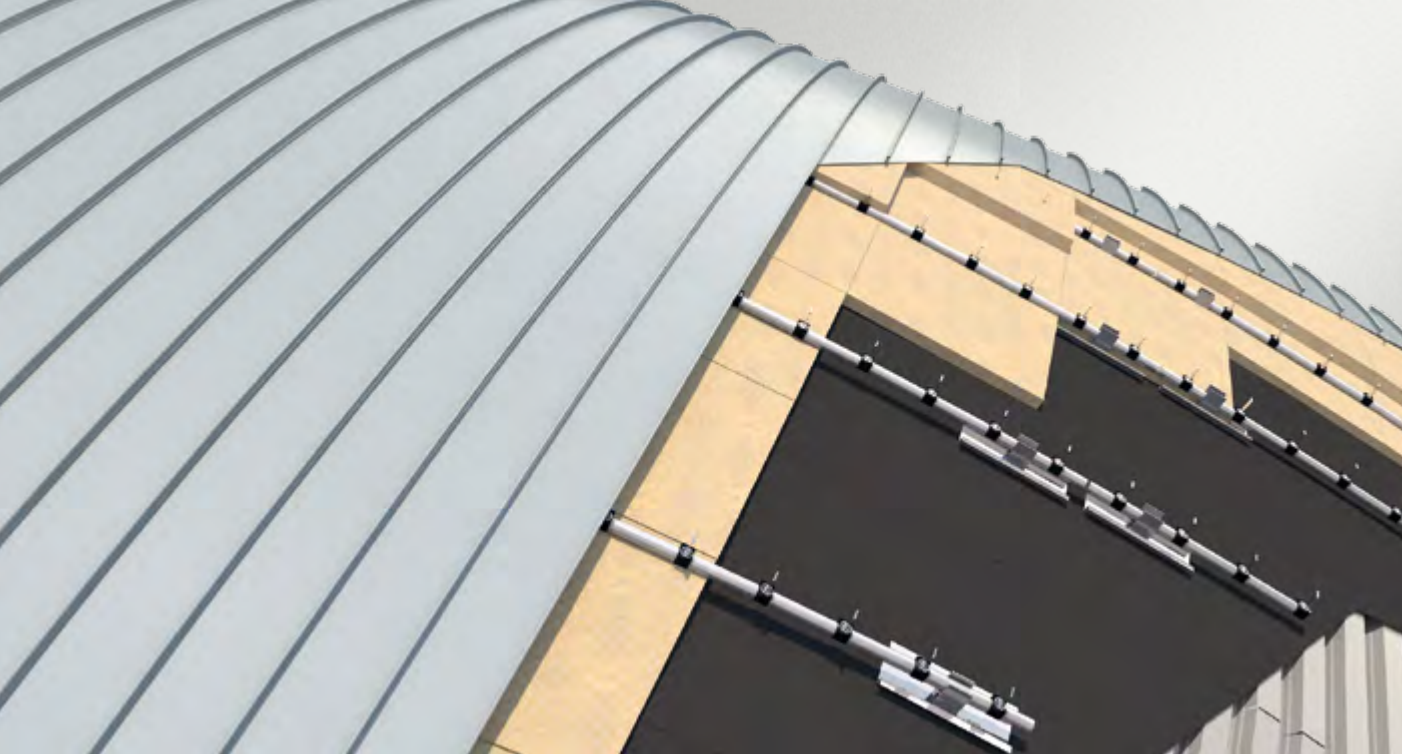

World cup football stadium natal // Brazil
 Architecture: Populous
 Photo: Archive BEMO do Brasil, Arena Dunas project –
 Canindé Soares photo

BEMO-DOME – SIMPLE AND FLEXIBLE COMPENSATION OF TOLERANCES



The BEMO-DOME substructure offers a highly flexible substructure solution that is right for cylindrical building shapes or those curved around 2 axes.

BEMO-DOME is primarily used for façades in sports stadiums, silos, oval towers (e.g. digester towers) or at the transition points between roof and façade.

Whether for a wall structure with or without back ventilation, BEMO-DOME substructure satisfies all requirements.

If you are aiming to obtain a perfect surface on the metal profiles for this substructure system, we recommend performing a 3D scan to record on-site measurements using BEMO 3D execution planning. This will give you a grid plan with the recommended mounting points with their positions and distance from the supporting structure.

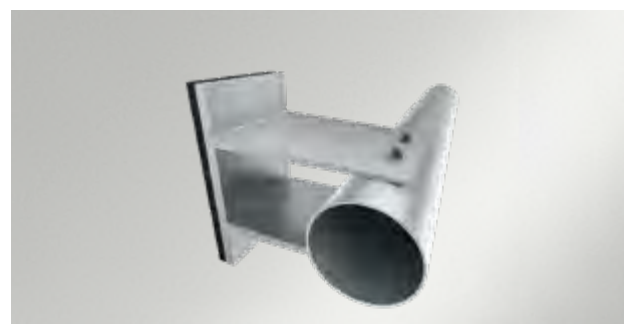
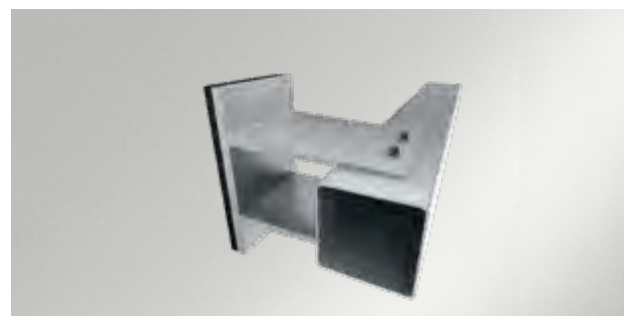

FACT SHEET

- HIGH LOAD-BEARING CAPACITY OF THE SYSTEM
- HIGH PRECISION THROUGH 3D MEASUREMENTS AND PLANNING
- SIMPLE ASSEMBLY ON SITE USING BEMO ASSEMBLY PLANNING
- OPTIMUM DESIGN SOLUTION FOR ROUNDED FAÇADE AREAS



PSV sports hall Salzburg // Austria
Photo: Peter Heimpel / PH-foto.de



Harrogate Event Centre // United Kingdom
Architecture: P & HS Architects

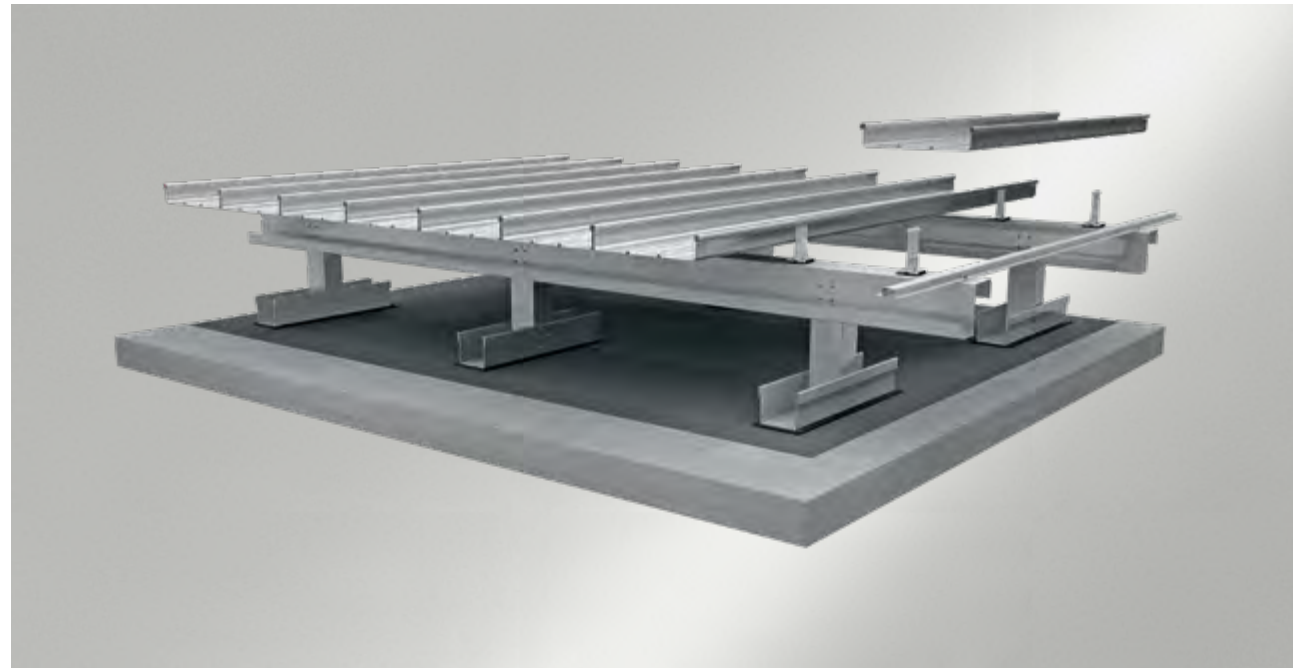

BEMO-ELEVATE – SUSTAINABLE AND DURABLE FLAT ROOF RENOVATION

BEMO-ELEVATE was developed specially for renovating old or damaged flat roofs.

Normally the old roofing system does not have to be removed. This allows business to continue as usual in the building while the roof is renovated.

Structural tests and building physics analysis are carried out at the start of a sustainable and durable renovation of a roof using metal profiles. In areas with rigid insulation, BEMO-ELEVATE can be applied directly to the existing roof area. Soft areas or areas where the supporting structure is not known are opened up and the ELEVATE profiles are screwed directly to the supporting surface.

Through the structure of the ELEVATE supporting structure we are able to give the roof a new, preferably slightly inclined shape for safe run-off of rainwater. The space created can be utilised to improve insulation of the building.

As a result you will have a new, very low-maintenance, very safe and durable roof.

Frequent repairs and maintenance work on the roof are things of the past.

FACT SHEET

- GOOD LOAD BEARING CAPACITY OF THE SYSTEM
- SUITABLE FOR ALMOST EVERY FLAT ROOF
- LOW MAINTENANCE AND DURABLE
- HIGH LEVEL OF PRE-ASSEMBLY IN THE WORKSHOP



BEMO ENGINEERING – FROM THE INITIAL DRAFT TO COMPLEX 3D PLANNING



BEMO has its own planning office staffed by experienced technicians and engineers and equipped with the latest 3D planning technology, some of which has been developed in-house.

From the initial consultation to implementation of the required design, the selection of materials and design, the first technical specifications and structural pre-analysis through to complete execution and workshop planning, BEMO is there for you.

LARGE IN-HOUSE PLANNING OFFICE WITH MANY YEARS OF INTERNATIONAL EXPERIENCE.

Cost estimates, technical optimisation and calculation of alternatives help you to optimise the economic feasibility of your project and ensure cost effectiveness.

3D measurements provide the basis for our sophisticated, yet easy to assemble systems and for implementation in 3D planning.

That is what we mean by a comprehensive partnership with BEMO.

BEMO IS THE NO 1 ADDRESS GLOBALLY FOR 3D COMPETENCE IN METALS.

FACT SHEET

- SYSTEM CONSULTING
- BASIC TECHNICAL EVALUATION
- TENDER SERVICE
- 3D MEASURING SERVICE OF THE BUILDING
- 3D IMPLEMENTATION PLANNING
- STRUCTURAL CALCULATIONS AND OPTIMISATION
- STRUCTURAL ANALYSIS OF THE SYSTEM
- CONSTRUCTION SITE SUPPORT

Tennis hall Triesen // Liechtenstein
 Photo: Andy Heinrich/vor-ort-foto.de



BEMO ROOF SYSTEMS – OPTIMUM BUILDING PHYSICS VALUES

 BEMO ROOF SYSTEMS ARE DESIGNED INDIVIDUALLY TO MEET THE NEEDS OF THE BUILDING.

Depending on the type of insulation package, BEMO roof systems achieve thermal transmission values of $<0.15 \text{ W/m}^2\text{K}$.

In addition to the requirements of building physics, cost-effectiveness, sustainability and, of course, easy, fast and safe assembly of a roof structure, all play an important role. In the case of very high thermal insulation requirements, we recommend roof structures with the largest possible percentage of soft insulation without using thermally combined with thermal bridge-free BEMO halters.

BEMO-SOFT (PLUS): Insulation layers made of “soft” insulation with GFK halters mounted directly on the supporting surface. Highly cost-effective. Up to $<0.173 \text{ W/m}^2\text{K}$.

BEMO-COMBI: Combination of soft and rigid insulation for improved soundproofing and thermal performance, without compromising construction depth.

BEMO-COMPACT: Very compact structure with rigid insulation for up to 360 mm insulation thickness and very good soundproofing values.

You will find an overview of the building physics values of the individual roof structures in the table.

Roof structures

	Insulation thickness mm	TC 032		TC 040	
		OHTC not distorted [W / mK]	OHTC considering thermal bridges [W / mK]	OHTC not distorted [W / mK]	OHTC considering thermal bridges [W / mK]
245 / 80 GFK halter directly on the load-bearing layer	180	0.172	0.173	0.213	0.214
140 / 60 aluminium halter with TK5 on 100 mm cap profile	180	0.172	0.360	0.213	0.375
245 / 80 GFK halter with cap profile 80 mm	260	0.120	0.130	0.149	0.150
220 / 60 aluminium halter with TK5 on 100 cap profile	260	0.120	0.273	0.149	–
160 / 60 aluminium halter with TK5 on 100 / 100 wood	200	0.171	0.323	0.202	0.353

Indicativ values without considering other components of the build up.

BEMO-SOFT

HEAT PROTECTION

relative halter height in mm:	80	100	120	140	160	180	200	220	240
Thick insulation layer in mm:	20	40	60	80	100	120	140	160	180
Total thickness roof construction in mm:	115	135	155	175	195	215	235	255	275
U-value without considering punctiform thermal bridges:	1.209	0.689	0.481	0.370	0.370	0.253	0.218	0.192	0.172

U-value considering punctiform thermal bridges

Aluminium Halter height:	80+TK5	100+TK5	120+TK5	140+TK5	160+TK5	180+TK5	200+TK5	220+TK5	
U-value:	1.386	0.860	0.646	0.529	0.453	0.399	0.358	0.326	
GFK Halter height:	85	105	125	145	165	185	205	225	245
U-value:	1.249	0.692	0.484	0.373	0.303	0.255	0.220	0.194	0.174

SOUND PROTECTION

Weight per m ² in kg:	12.45	12.85	13.25	13.65	14.05	14.45	14.85	15.25	15.65
predictable sound reduction index R in dB:	33.88	34.16	34.42	34.68	34.93	35.18	35.41	35.64	35.87

Measures to improve sound insulation: Use of insulating materials with 70kg/m³

Weight per m ² in kg:	16.43	17.83	19.23	20.63	22.03	23.43	24.83	26.23	27.63
predictable sound reduction index R in dB:	36.29	37.00	37.66	38.27	38.84	39.37	39.88	40.36	40.81

Installation of a layer of gypsum board with 8.5 kg/m²:

Weight per m ² in kg:	20.95	21.35	21.75	22.15	22.55	22.95	23.35	23.75	24.15
predictable sound reduction index R in dB:	38.40	38.57	38.73	38.89	39.04	39.20	39.35	39.49	39.64

Installation of a soundproofing panel with 17.5kg/m²

Weight per m ² in kg:	29.95	30.35	30.75	31.15	31.55	31.95	32.35	32.75	33.15
predictable sound reduction index R in dB:	41.51	41.62	41.74	41.85	41.96	42.07	42.18	42.28	42.39

The values mentioned are reference values.

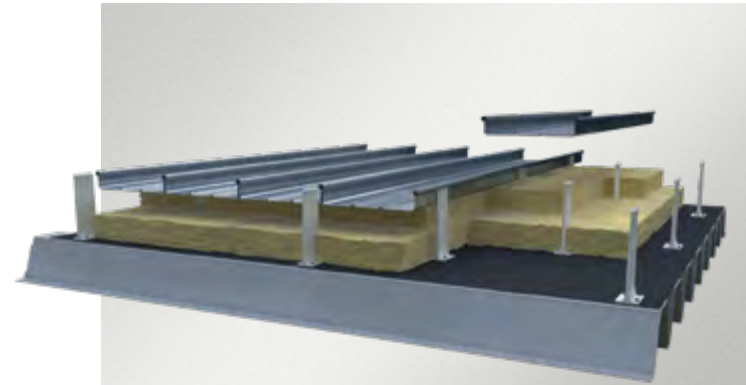

- ❖ BEMO standing seam profile 65-400, 1.0 mm aluminium
- ❖ Aluminium-Halter incl. 5 mm Thermal Spacer GFK Halter 1.5 pcs/m²
- ❖ Mineral wool insulation 035, 20 kg/m³
- ❖ Vapour barrier
- ❖ Decking 0.75 mm steel

Main uses

- ❖ Structures of steel, timber or concrete
- ❖ Buildings with high thermal insulation and soundproofing requirements

Benefits

- ❖ Low dead weight
- ❖ Heat bridges caused by the system can be avoided
- ❖ Fast and easy construction

BEMO-SOFT PLUS

HEAT PROTECTION

relative halter height in mm:	80	100	120	140	160	180	200	220
Thick insulation layer in mm:	120	140	160	180	200	220	240	260
Total thickness roof construction in mm:	215	235	255	275	295	315	335	355
U-value without considering punctiform thermal bridges:	0.253	0.218	0.192	0.172	0.155	0.141	0.130	0.120

U-value considering punctiform thermal bridges

Aluminium Halter height:	80+TK5	100+TK5	120+TK5	140+TK5	160+TK5	180+TK5	200+TK5	220+TK5
U-value:	0.467	0.423	0.388	0.360	0.334	0.311	0.292	0.273
GFK Halter height:	85	105	125	145	165	185	205	225
U-value:	0.291	0.253	0.223	0.199	0.178	0.161	0.145	0.131

SOUND PROTECTION

Weight per m ² in kg:	17.43	17.83	18.23	18.63	19.03	19.43	19.83	20.23
predictable sound reduction index R in dB:	36.81	37.00	37.20	37.38	37.57	37.75	37.93	38.10

Measures to improve sound insulation: Use of insulating materials with 70kg/m³

Weight per m ² in kg:	23.43	24.83	26.23	27.63	29.03	30.43	31.83	33.23
predictable sound reduction index R in dB:	39.37	39.88	40.36	40.81	41.24	41.65	42.04	42.41

Installation of a layer of gypsum board with 8.5 kg/m²:

Weight per m ² in kg:	25.93	26.33	26.73	27.13	27.53	27.93	28.33	28.73
predictable sound reduction index R in dB:	40.26	40.39	40.52	40.65	40.78	40.90	41.02	41.15

Installation of a soundproofing panel with 17.5kg/m²

Weight per m ² in kg:	34.93	35.33	35.73	36.13	36.53	36.93	37.33	37.73
predictable sound reduction index R in dB:	42.84	42.94	43.04	43.14	43.23	43.33	43.42	43.51

The values mentioned are reference values.

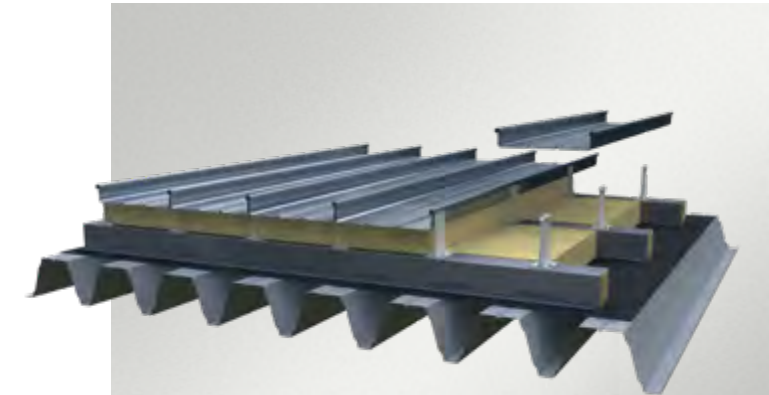

- ❖ BEMO standing seam profile 65-400, 1.0 mm aluminium
- ❖ Aluminium-Halter incl. 5 mm Thermal Spacer GFK Halter 1.5 pcs/m²
- ❖ Top hat 100 mm, centres 1.5 m
- ❖ Mineral wool insulation 032, 20 kg/m³
- ❖ Vapour barrier
- ❖ Decking 0.75 mm steel

Main uses

- ❖ Purlin construction
- ❖ Structures of steel, timber or concrete

Benefits

- ❖ Low dead weight
- ❖ Heat bridges caused by the system can be avoided
- ❖ Very low u-values
- ❖ Good summer heat protection



BEMO-SOFT PLUS OVER A CONCRETE SUBSTRUCTURE

HEAT PROTECTION

relative halter height in mm:	80	100	120	140	160	180	200	220	240	260
Thick insulation layer in mm:	120	140	160	180	200	220	240	260	280	300
Total thickness roof construction in mm:	415	435	455	475	495	515	535	555	575	595
U-value without considering punctiform thermal bridges:	0.268	0.232	0.205	0.184	0.166	0.152	0.140	0.129	0.120	0.113

U-value considering punctiform thermal bridges

Aluminium Halter height:	80+TK5	100+TK5	120+TK5	140+TK5	160+TK5	180+TK5	200+TK5	220+TK5	220+TK15	260 fictive
U-value:	0.472	0.427	0.391	0.362	0.335	0.312	0.292	0.273	0.255	0.240
GFK Halter height:	85	105	125	145	165	185	205	225	245	245+DK20
U-value:	0.293	0.255	0.225	0.202	0.181	0.165	0.150	0.136	0.126	0.118

SOUND PROTECTION

Weight per m ² in kg:	490.13	490.53	490.53	491.33	491.73	492.13	492.53	492.93	493.33	493.73
predictable sound reduction index R in dB:	65.79	65.79	65.79	65.81	65.81	65.82	65.83	65.84	65.84	65.85

Measures to improve sound insulation: Use of insulating materials with 70kg/m³

Weight per m ² in kg:	496.13	497.53	498.93	500.33	501.73	503.13	504.53	505.93	507.33	508.73
predictable sound reduction index R in dB:	65.89	65.92	65.94	65.96	65.99	66.01	66.04	66.06	66.09	66.11

Installation of a layer of gypsum board with 8.5 kg/m²:

Weight per m ² in kg:	498.63	499.03	499.03	499.83	500.23	500.63	501.03	501.43	501.83	502.23
predictable sound reduction index R in dB:	65.93	65.94	65.94	65.96	65.96	65.97	65.98	65.98	65.99	66.00

Installation of a soundproofing panel with 17.5kg/m²

Weight per m ² in kg:	507.63	508.03	508.03	508.83	509.23	509.63	510.03	510.43	510.83	511.23
predictable sound reduction index R in dB:	66.09	66.10	66.10	66.11	66.12	66.12	66.13	66.14	66.14	66.15

The values mentioned are reference values.

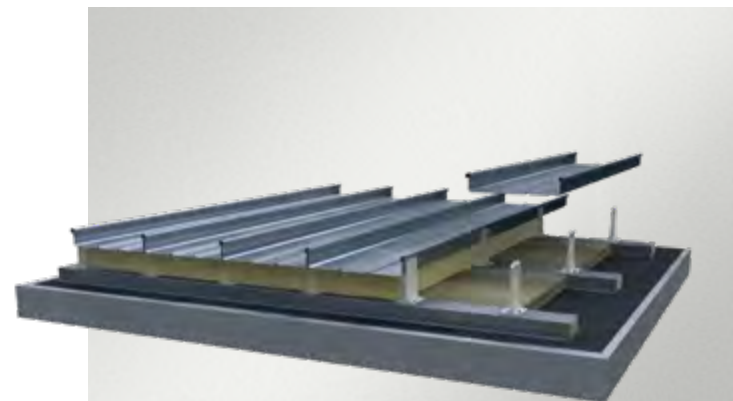

- ❖ BEMO standing seam profile 65-400, 1.0 mm aluminium
- ❖ Aluminium-Halter incl. 5 mm Thermal Spacer GFK Halter 1.5 pcs/m²
- ❖ Top hat 100 mm, centres 1.5 m
- ❖ Mineral wool insulation 035, 20 kg/m³
- ❖ Vapour barrier
- ❖ 20 cm concrete deck

Main uses

- ❖ All kinds of concrete deck
- ❖ Buildings with high soundproofing demands

Benefits

- ❖ Reduction of thermal bridges
- ❖ High sound insulation
- ❖ Low u-values
- ❖ Very good summer heat protection

BEMO-COMBI

HEAT PROTECTION

relative halter height in mm:	80	100	120	140	160	180	200	220	240	260
Thick insulation layer in mm:	120	140	160	180	200	220	240	260	280	300
Total thickness roof construction in mm:	215	235	255	275	295	315	335	355	375	395
U-value without considering punctiform thermal bridges:	0.290	0.251	0.221	0.197	0.178	0.163	0.150	0.138	0.129	0.120

U-value considering punctiform thermal bridges

Aluminium Halter height:	80+TK5	100+TK5	120+TK5	140+TK5	160+TK5	180+TK5	200+TK5	220+TK5	220+TK15	260 fictive
U-value:	0.488	0.440	0.401	0.368	0.341	0.316	0.295	0.276	0.258	0.242
GFK Halter height:	85	105	125	145	165	185	205	225	245	245+DK20
U-value:	0.306	0.266	0.234	0.209	0.188	0.172	0.157	0.143	0.133	0.123

SOUND PROTECTION

Weight per m ² in kg:	22.45	22.85	23.25	23.65	24.05	24.45	24.85	25.25	25.65	26.05
predictable sound reduction index R in dB:	39.00	39.16	39.31	39.46	39.60	39.74	39.89	40.02	40.16	40.30

Measures to improve sound insulation: Use of insulating materials with 70kg/m³

Weight per m ² in kg:	24.43	27.83	31.23	34.63	38.03	41.43	44.83	48.23	51.63	55.03
predictable sound reduction index R in dB:	39.74	40.87	41.87	42.77	43.58	44.33	45.01	45.65	46.24	46.79

Installation of a layer of gypsum board with 8.5 kg/m²:

Weight per m ² in kg:	30.95	31.35	31.75	32.15	32.55	32.95	33.35	33.75	34.15	34.55
predictable sound reduction index R in dB:	41.79	41.90	42.01	42.12	42.23	42.34	42.44	42.54	42.65	42.75

Installation of a soundproofing panel with 17.5kg/m²

Weight per m ² in kg:	39.95	40.35	40.75	41.15	41.55	41.95	42.35	42.75	43.15	43.55
predictable sound reduction index R in dB:	44.01	44.10	44.18	44.27	44.35	44.43	44.52	44.60	44.68	44.76

The values mentioned are reference values.

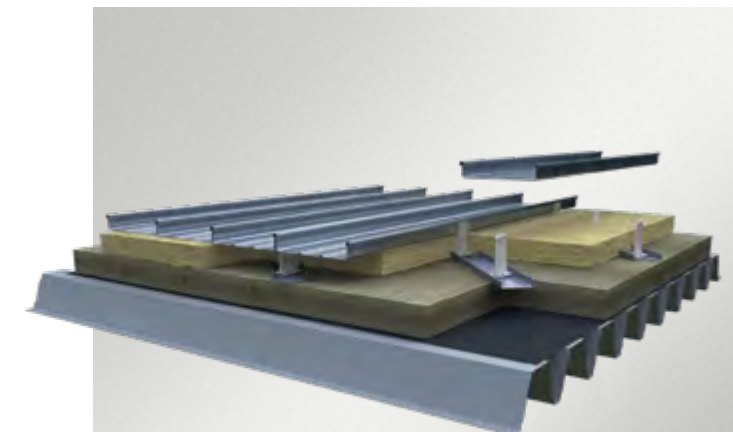

- ❖ BEMO standing seam profile 65-400, 1.0 mm aluminium
- ❖ Aluminium-Halter incl. 5 mm TK Thermal Spacer GFK Halter 1.5 pcs/m²
- ❖ 1st layer of stone wool insulation 037, 100 kg/m³ 10 cm
- ❖ 2nd layer Mineral wool insulation 035, 20 kg/m³
- ❖ Vapour barrier
- ❖ Decking 0.75 mm steel

Main uses

- ❖ Structures of steel, timber or concrete
- ❖ Buildings with increased requirements for heat and sound protection

Benefits

- ❖ Reduction of thermal bridge
- ❖ High sound insulation
- ❖ Good summer heat protection

BEMO-COMPACT

HEAT PROTECTION

relative halter height in mm:	80	100	120	140	160	180	200	220	240	260
Thick insulation layer in mm:	120	140	160	180	200	220	240	260	280	300
Total thickness roof construction in mm:	215	235	255	275	295	315	335	355	375	395
U-value without considering punctiform thermal bridges:	0.290	0.251	0.221	0.197	0.178	0.163	0.150	0.138	0.129	0.120

U-value considering punctiform thermal bridges

Aluminium Halter height:	80+TK5	100+TK5	120+TK5	140+TK5	160+TK5	180+TK5	200+TK5	220+TK5	220+TK15	260 fictive
U-value:	0.465	0.420	0.384	0.355	0.329	0.308	0.289	0.271	0.257	0.242
GFK Halter height:	85	105	125	145	165	185	205	225	245	245+DK20
U-value:	0.294	0.254	0.224	0.200	0.180	0.165	0.152	0.140	0.130	0.121

SOUND PROTECTION

Weight per m ² in kg:	24.05	26.05	28.05	30.05	32.05	34.05	36.05	38.05	40.05	42.05
predictable sound reduction index R in dB:	39.60	40.30	40.94	41.54	42.10	42.62	43.12	43.59	44.03	44.45

Measures to improve sound insulation:

Installation of a layer of gypsum board with 8.5 kg/m²:

Weight per m ² in kg:	32.55	34.55	36.55	38.55	40.55	42.55	44.55	46.55	48.55	50.55
predictable sound reduction index R in dB:	42.23	42.75	43.24	43.70	44.14	44.56	44.96	45.34	45.70	46.05

Installation of a soundproofing panel with 17.5kg/m²

Weight per m ² in kg:	41.55	43.55	45.55	47.55	49.55	51.55	53.55	55.55	57.55	59.55
predictable sound reduction index R in dB:	44.35	44.76	45.15	45.52	45.88	46.22	46.55	46.87	47.18	47.48

The values mentioned are reference values.

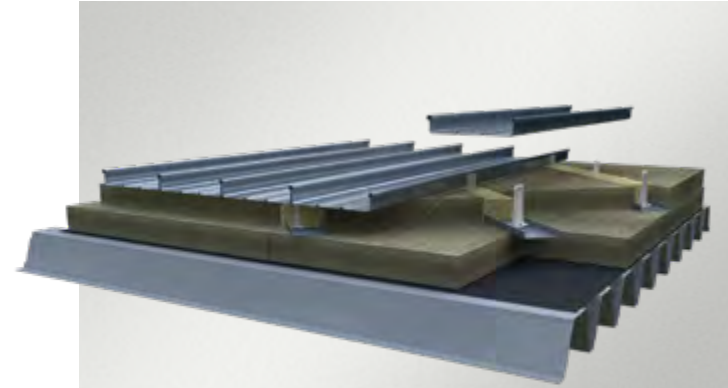

- ❖ BEMO standing seam profile 65 – 400, 1.0 mm aluminium
- ❖ Aluminium-Halter incl. 5 mm Thermal Spacer GFK Halter 1.5 pcs/m²
- ❖ 1st layer of stone wool insulation 037, 100 kg/m³ 10 cm
- ❖ 2nd layer of stone wool insulation 037, 100 kg/m³ 10 cm
- ❖ Vapour barrier
- ❖ Decking 0.75 mm steel

Main uses

- ❖ Structures of steel, timber or concrete
- ❖ Buildings with increased requirements for heat and sound protection

Benefits

- ❖ Reduction of thermal bridge
- ❖ Very high sound insulation
- ❖ Very good summer heat protection
- ❖ Perfect load transfer at high snow masses

BEMO VENTILATED / COLD ROOFS

PROTECTION AGAINST CONDENSATION

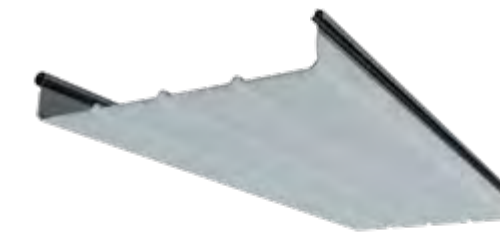

Due to temperature differences between inside and outside condensation might occur on the inside of the single skin. Fleece will absorb moisture and release it later.

ANTI-DRUMMING SOLUTIONS

By using a noise reducing film, raindrumming sounds can be effectively reduced.

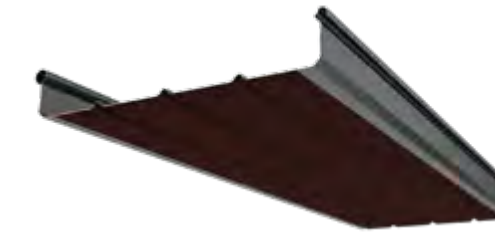

Reduction of noise by using noise reducing film

Frequency in Hz:	50	100	200	400	800	1600	4000	Noise level in dB
weighted sound pressure dBA with dedpan:	9.7	25.6	35	44.4	43.2	43.4	37.5	53.7
weighted sound pressure dBA without dedpan:	8.6	21.2	28.4	36.1	35.6	33.3	26.3	45.4

The values mentioned are reference values.

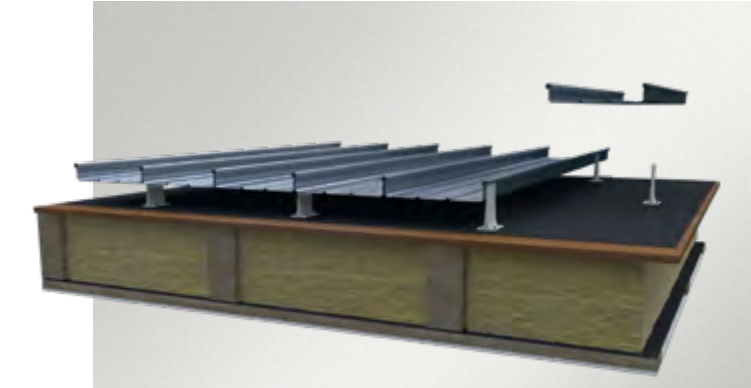

- ❖ Recommended profile width 400 mm
- ❖ Minimum material thickness 1 mm
- ❖ Usage of aluminium halter

Main uses

- ❖ Ventilated or single skin roofs

Benefits

- ❖ Seamless roof
- ❖ Possibility of avoiding trapped condensation water by using fleece
- ❖ Reduction of raindrumming effect by using a noise reducing film

CALCULATIONS ON A SOUND BASIS – OUR EXPERIENCE

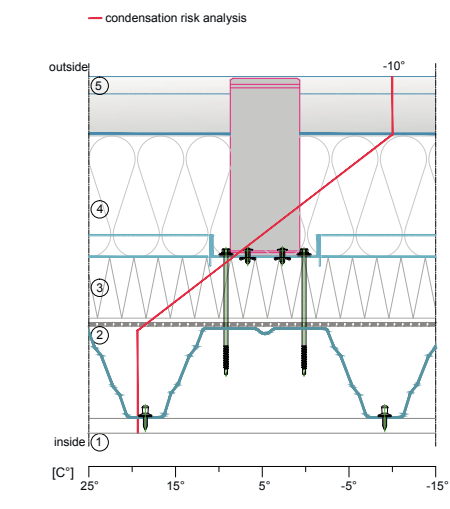
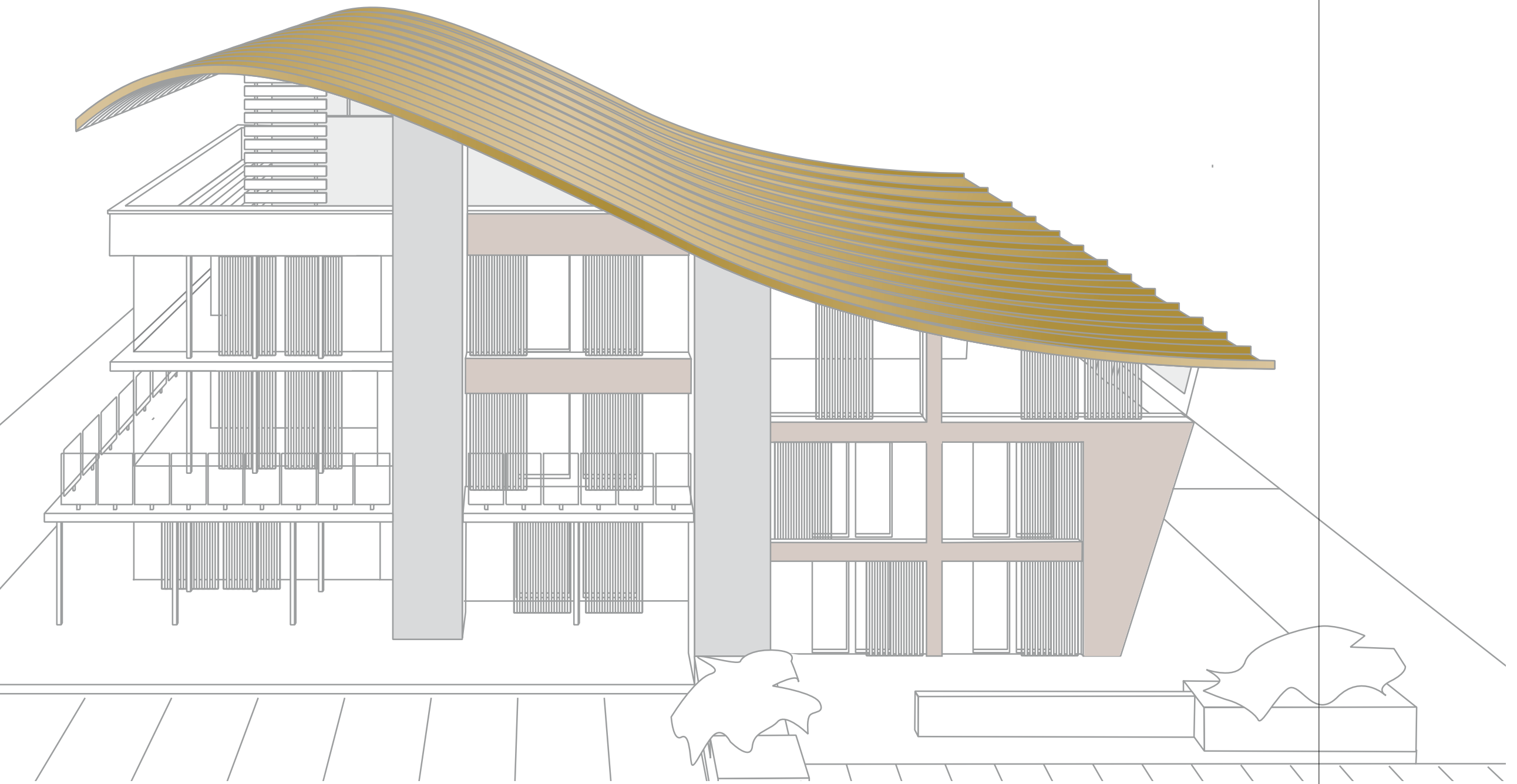

STRUCTURAL CALCULATIONS / DESIGN SOLUTIONS:
 Every building, every superstructure and every design requires proof of structural soundness based on standards, system approval or simply on the basis of historical data collected. The spectrum of requirements is extensive. European standards are often difficult to understand and keep abreast of. That is why it is all the more important to have a professional, reliable systems partner who is familiar with requirements and structural conditions and can do the necessary calculations himself. At BEMO we can do that for you.

BUILDING PHYSICS PROOF:
 The interaction of the requirements of structural analysis and building physics and customers' preferences can be challenging at times. It is exactly at this point that BEMO can offer solutions and approaches that take all requirements into account. Using tried and tested system solutions. Using special solutions based on experience.

Building physics proof rounds off our "Engineering" service package. Benefit from our experience, our calculation tools and our knowledge which has been built up over years of practical implementation. Soundproofing and thermal and moisture insulation are in good hands at BEMO.



Skolkovo Institute Of Science, Moskau // Russia
Architecture: Herzog & de Meuron



Convention Center, Lausanne // Switzerland
Architecture: Richter Dahl Rocha & Associés architectes
Photo: Sérgio Guerra

BEMO SMOOTH – HIGH-END DESIGN WITH THE ADDITIONAL FACTOR OF SAFETY

THE TREND IN BUILDING DESIGN:
A SMOOTH, COLOURFUL, SEGMENTED
BUILDING ENVELOPE.

Contemporary architecture calls more and more for a smooth, metal building envelope. BEMO-SMOOTH provides a safe and easy option to build smooth surfaces without penetrating the water-bearing layer comprised of BEMO standing seam profiles. The BEMO-TOP mounting profile can be applied by the seaming machine in a second work step without penetrating the BEMO standing seam.

The water-bearing layer is not penetrated and so remains undamaged and functional. The practically maintenance-free standing seam roof is both accessible and very robust mechanically. No additional sealing is required on the roof system.

The BEMO-TOP mounting profiles facilitate the sliding ability of the standing seam system when thermal linear expansion occurs. The smooth roof façade can be attached onto the flange of these rails.

Rounded transitions from the roof into the façade are possible using the arched standing seam profiles. Even freeform areas can be created as smooth surfaces with MONRO profiles and the BEMO-SMOOTH system.

The BEMO-SMOOTH system provides a safe solution for almost every type of architecturally demanding shape of roof and façade.

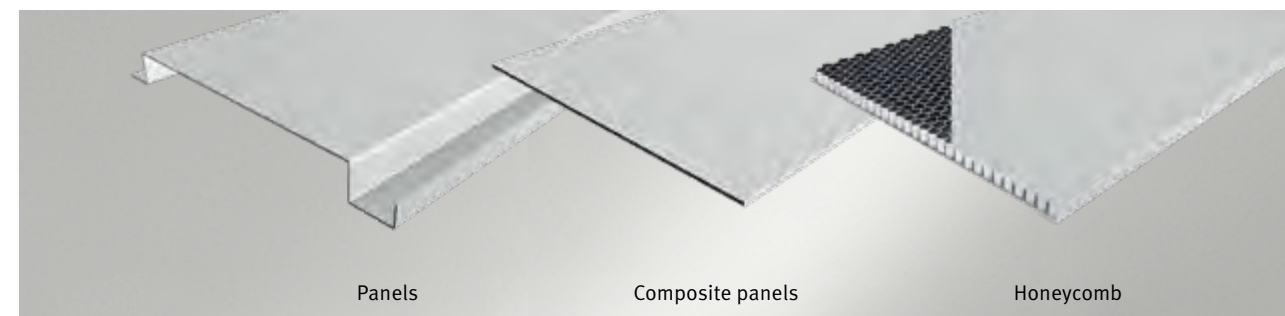
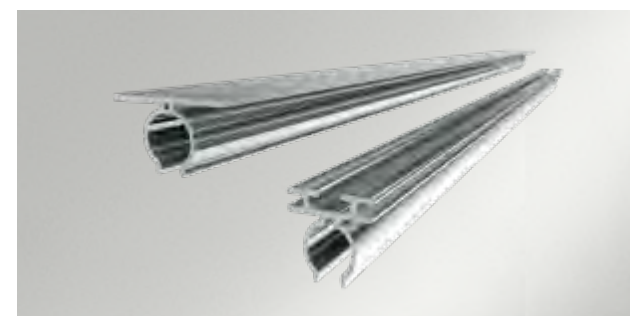

Panels

Composite panels

Honeycomb

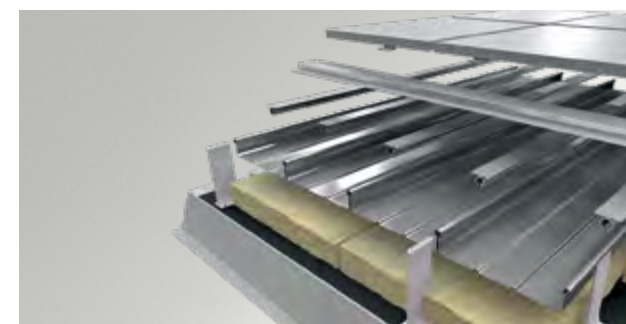
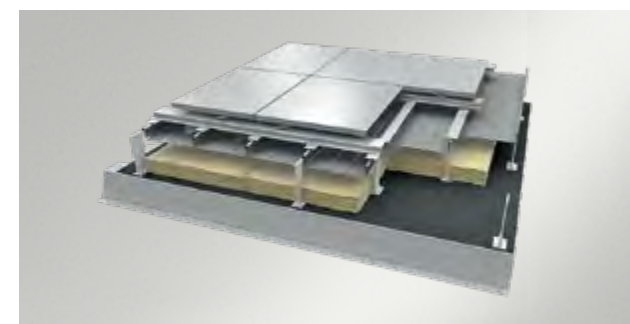
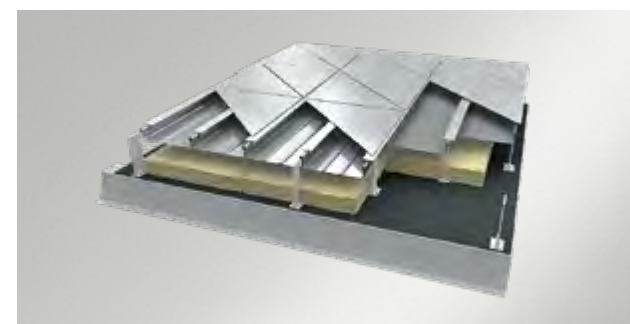

FACT SHEET

- SMOOTH BUILDING ENVELOPE
- THE WATER-BEARING LAYER IS NOT PENETRATED
- ROBUST & WALKABLE
- SIMPLE ASSEMBLY OF THE DESIGN SURFACE
- SAFE THERMAL EXPANSION



Airport Zagreb // Croatia
 Architecture: IGH d.d. & Neidhardt arhitekti d.o.o. & Kincl d.o.o.
 Photo: MZLZ/Josip Škof

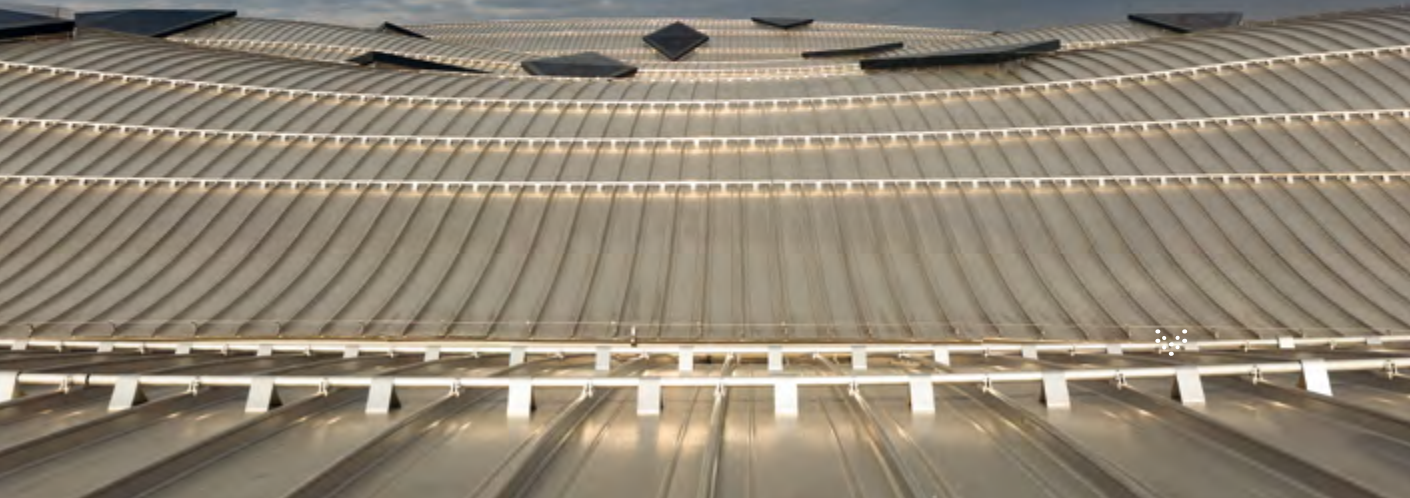

BEMO – ROOF STRUCTURES

SOLUTIONS USING ROOF STRUCTURES MUST BE ONE THING ABOVE ALL: SAFE. LIKE BEMO SYSTEM SOLUTIONS.

MANSAFE SYSTEM

The BEMO mansafe system, approved by building authorities, has been designed specifically for transverse forces in the area of the gableboard, complying with the latest European standards for roof safety systems. We will be happy to design the system individually to match your project. We will also deliver the assembly plan with the system parts.

SNOW GUARD SYSTEMS

Our snow guard systems are adapted to the profile geometry of BEMO standing seam tracks.

On request the system parts, which are not painted as standard, can be matched to the colour of the roof area and supplied in a powder-coated version. Numerous special systems are also available to satisfy special requirements.

Attachment points tested for bearing loads and shear loads are required for railings and walkways with gratings. The variable BEMO EAP solutions offer the right solution for every requirement.

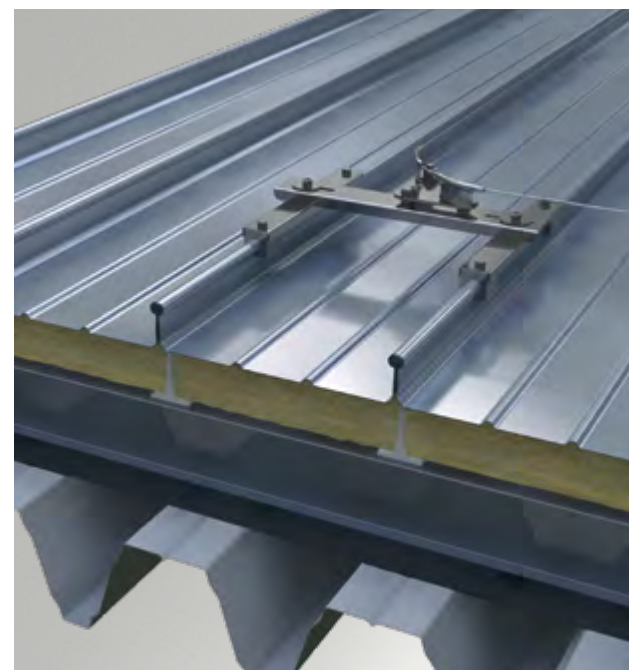
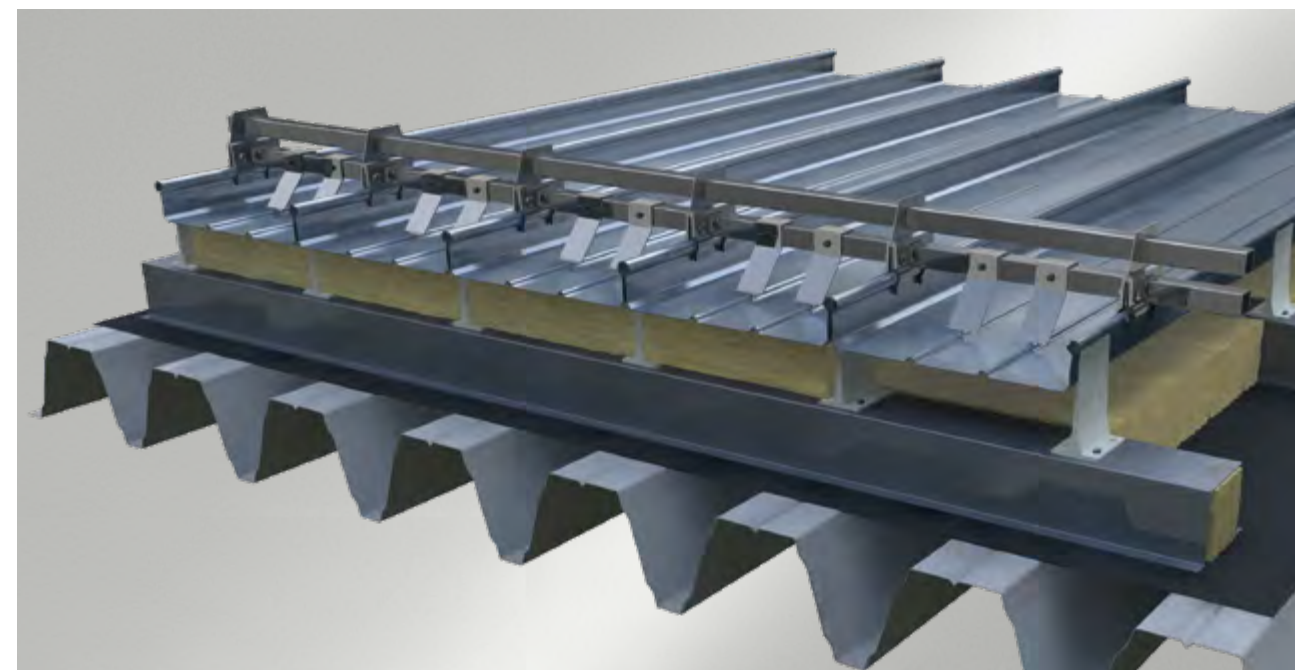

FACT SHEET

- TESTED ANTI-FALL SAFETY
- INDIVIDUAL ATTACHMENT POINTS CAN BE APPLIED FLEXIBLY
- SNOW GUARD SYSTEMS ALSO AVAILABLE IN COLOUR
- TECHNICAL ADVICE FOR ALL SYSTEM PARTS



COLOURS

COLOURS	METALLIC					NATURAL		
	Anthracite metallic	Silver metallic	Grey metallic	Eurazinc	Sandstone metallic		Red Terra metallic	
	ELEGANT							
	Naturalgreen metallic	Bronze metallic (504)	Ink Black (326)	Smoke Silver (501)	Grey metallic (502)	Champagne Silver (503)		
INTENSE								
Deep Grey metallic (505)	Copper Metallic	Sunrise Silver (600)	Intense Red 75	Intense Yellow 75	Intense Orange 75			
ANODIZED COLOURS								
Intense Blue 75	Intense Green 75	Anodized B 10	Anodized B 20	Anodized B 30	Anodized B 40			

The colours shown are non-binding samples. The shades may differ from the original colours on our metal profiles.

A SHEER ENDLESS VARIETY OF DESIGN OPTIONS – COLOURS AND SURFACES

METALS

Aluminium	Steel	Copper	Stainless steel	Titanium zinc

SURFACES

Stucco	Brushed	Zinc-aluminium	Pre-weathered	BEMO-FLON®

HOLE PATTERNS

Rv 3-5	Rv 5-8	SW 11-14	Qd 7.5-11.5	Lg 1x20-2.5x24

Ferrari Car Showroom // Austria
 Architecture: Götz Seidel & ATMOS Architekten ZT OG
 Photo: Mili Martinez-Flener/vor-ort-foto.de



Competition standard sports hall // Germany
 Architecture: Alten Architekten, Mr Dirk Alten
 Photo: Klemens Ortmeier



Family Centre SOS Kinderdorf e.V. // Germany
 Architecture: Thalen Consult, Maike Winter
 Photo: S + T Fassaden GmbH

BEMO IS YOUR PARTNER FOR EXCELLENCE IN ARCHITECTURE – FOR FAÇADES AND ROOFS



BEMO offers a unique range of services for metal roofs of all sizes, for every roof shape and for every climate zone. BEMO is the undisputed global leader in technology for complex metal-roof projects.

Based on this experience our BEMO FAÇADE SYSTEMS stand for BEMO's claims for its systems: Versatile, easy to assemble, excellent design - and perfect planning - from our in-house planning office.

Using our patented assembly systems which, of course, have been approved by building authorities, we make the assembly of very large façade sheets easy and safe.

BEMO has the knowledge and technology to implement your ideas. This is how visions become reality for buildings designed from a single source of inspiration – you.

Warehouses // Germany
 Architecture: Schmelzle + Partner GmbH
 Photo: Ulrich Marx / vor-ort-foto.de



WWW.BEMO.COM

BEMO SYSTEMS GmbH

Max-Eyth-Straße 2
74532 Ilshofen-Eckartshausen
Germany

T: +49 7904 29899-60
F: +49 7904 29899-61
E: sales@bemo.com
W: www.bemo.com

BEMO Project Engineering UK Ltd.

Jessop House, Outrams Wharf,
Little Eaton,
Derbyshire, DE21 5EL,
United Kingdom

T: +44 1773 853 694
E: sales@bemouk.com
W: www.bemo.com/en-uk

BEMO Dış Cephe Çatı Kaplama

Sistemleri Ticaret ve Sanayi Ltd.Sti
Göktürk Cad. Suvenue Sitesi C Blok
Daire 7, Göktürk, 34077
İstanbul – Türkiye

T: +90 2123 227 472
F: +90 2123 227 574
E: pazarlama@bemo.com
W: www.bemo.com

BEMO SYSTEMS GmbH

Via Serbelloni 47
20064 Gorgonzola (MI)
Italy

T: +39 02 365 420 81
E: servizio@bemo.com
W: www.bemo.com

BEMO SYSTEMS GmbH

Volgogradsky Av. 43 bld. 3
office 166
109316, Moscow
Russian Federation

T: +7917 508 78 30
E: sales.russia@bemo.com
W: www.bemo.com