



DRYWALL STEEL SECTIONS



Light Steel Framing (LSF) Product Information

Drywall Steel Sections Ltd (DSSL)

is one of the leading manufacturers of high quality steel sections, for the ceiling and drywall partitioning markets and external applications. With a combined experience spanning more than 40 years coupled with widespread expertise and product knowledge, DSSL is able to offer its clients both high quality and competitive products.

DSSL has one of the most comprehensive ranges of Cold Rolled Products for use in the external framing, facade and envelope applications.

All components are of a high quality, accurately manufactured whilst remaining cost competitive, and is supported by continuing research, development and testing. This has been further enhanced by the recent capital investment in up to date state-of-the-art roll forming technology.



1**STUD & TRACK SECTION PROPERTIES**

Manufactured in accordance with BS EN 10326:2004 in S450 GD+Z275 material grade. All DSS sections are manufactured to close tolerance with a thorough inspection procedure before despatch. These section tables detail the critical dimensions and elements of each section. The list of products is not exhaustive as bespoke sections can be provided upon request.
page 4

2**STUD & TRACK SECTION DIMENSIONS**

To ensure that the correct through wall specification is designed, DSS provide full sectional dimensions for its range of products. The intention of these tables is to provide an approximate guide to designers to use in the early design stages.
page 5

3**ACCESSORIES**

A full range of standard SFS system accessories that also apply in cladding and rainscreen systems. Bespoke sections are also available to suit any type of design, produced using our CNC controlled pressbraking department, including the latest in 4m pressbrakes.
page 6

4**CONSTRUCTION EXAMPLES**

A sample set of typical SFS details, showing some full system details that are supported from DSS light gauge steel sections.
page 7

5**TYPICAL DETAILS**

Showing the various types of standard connection methods for or SFS system .
pages 8 and 9

6**TRANSPORT & LOGISTICS**

Drywall delivery information.
page 9

7**PARTITIONING & CEILING SYSTEMS**

Drywall non-load bearing partitions, MF ceiling system and wall liner system.
pages 10 and 11

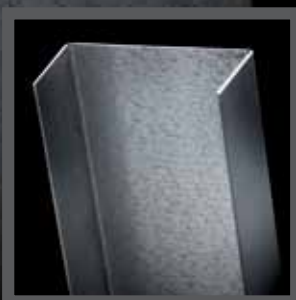

1 STUD & TRACK SECTION - PROPERTIES

Manufactured in accordance with BS EN 10326:2004 in S450 GD+Z275 material grade. All DSS sections are manufactured to close tolerance with a thorough inspection procedure before despatch. These section tables detail the critical dimensions and elements of each section. The list of products is not exhaustive as bespoke sections can be provided upon request.

C STUD SECTION - Available in lengths of up to 12 metres.

dimensions					properties												
section reference	depth (Dmm)	flange (Wmm)	return (Rmm)	gauge (Tmm)	weight (kg/m)	area (cm ²)	I _{xx} (cm ⁴)	I _{yy} (cm ⁴)	Z _{xx} (cm ³)	Z _{yy1} (cm ³)	Z _{yy2} (cm ³)	R _{xx} (cm)	R _{yy} (cm)	C _y (mm)	C _x (mm)	PO (N/mm ²)	Mc (Nmm)
C.100.50.12	100	50	10	1.2	2.02	2.66	42.76	8.71	8.55	5.62	2.52	4.01	1.81	15.5	50.0	376.42	3.22
C.100.60.12	100	60	10	1.2	2.21	2.90	48.61	13.57	9.72	6.96	3.35	4.09	2.16	19.5	50.0	376.42	3.66
C.100.50.15	100	50	10	1.5	2.51	3.20	52.80	10.70	10.56	6.67	3.15	4.06	1.83	16.0	50.0	392.66	4.15
C.100.60.15	100	60	10	1.5	2.74	3.50	60.08	16.70	12.02	8.31	4.19	4.14	2.18	20.1	50.0	392.66	4.72
C.100.50.20	100	50	10	2.0	3.32	4.10	68.98	13.88	13.80	8.38	4.15	4.10	1.84	16.6	50.0	408.91	5.64
C.100.60.20	100	60	10	2.0	3.63	4.50	78.58	21.74	15.72	10.50	5.53	4.18	2.20	20.7	50.0	408.91	6.43
C.150.50.12	150	50	10	1.2	2.49	3.26	108.75	9.86	14.50	7.73	2.65	5.77	1.74	12.8	75.0	335.80	4.87
C.150.50.15	150	50	10	1.5	3.10	3.95	134.63	12.11	17.95	9.22	3.29	5.84	1.75	13.1	75.0	360.17	6.47
C.150.50.20	150	50	10	2.0	4.10	5.10	176.63	15.71	23.55	11.62	4.31	5.88	1.75	13.5	75.0	384.54	9.06
C.150.60.12	150	60	10	1.2	2.68	3.50	122.04	15.44	16.27	9.50	3.53	5.90	2.10	16.3	75.0	335.80	5.46
C.150.60.15	150	60	10	1.5	3.33	4.25	151.17	19.01	20.16	11.39	4.39	5.96	2.11	16.7	75.0	360.17	7.26
C.150.70.15	150	70	15	1.5	3.68	4.70	173.57	31.45	23.14	14.28	6.55	6.08	2.59	22.0	75.0	360.17	8.34
C.150.70.20	150	70	15	2.0	4.88	6.10	228.25	41.13	30.43	18.27	8.66	6.12	2.60	22.5	75.0	384.54	11.70
C.200.50.12	200	50	10	1.2	2.96	3.86	214.52	10.65	21.45	9.79	2.72	7.45	1.66	10.9	100.0	295.18	6.33
C.200.70.12	200	70	10	1.2	3.33	4.34	261.95	24.62	26.19	14.25	4.67	7.77	2.38	17.3	100.0	295.18	7.73
C.200.50.15	200	50	10	1.5	3.68	4.70	265.96	13.08	26.60	11.72	3.37	7.52	1.67	11.2	100.0	327.68	8.71
C.200.50.20	200	50	10	2.0	4.88	6.10	349.76	16.95	34.98	14.78	4.40	7.57	1.67	11.5	100.0	360.17	12.60
C.200.70.12	200	70	15	1.2	3.43	4.46	271.14	27.83	27.11	14.89	5.42	7.79	2.50	18.7	100.0	295.18	8.00
C.200.70.15	200	70	15	1.5	4.27	5.45	336.55	34.37	33.65	18.00	6.75	7.86	2.51	19.1	100.0	327.68	11.03
C.200.70.20	200	70	15	2.0	5.66	7.10	443.49	44.93	44.35	23.06	8.90	7.90	2.52	19.5	100.0	360.17	15.97
C.250.70.12	250	70	15	1.2	3.90	5.06	457.03	29.62	36.56	17.90	5.54	9.50	2.42	16.5	125.0	254.57	9.31
C.250.50.15	250	50	15	1.5	4.39	5.60	475.13	16.15	38.01	14.94	4.12	9.21	1.70	10.8	125.0	295.18	11.22
C.250.70.15	250	70	15	1.5	4.86	6.20	567.76	36.58	45.42	21.68	6.89	9.57	2.43	16.9	125.0	295.18	13.41
C.250.70.20	250	70	15	2.0	6.44	8.10	749.20	47.82	59.94	27.79	9.06	9.62	2.43	17.2	125.0	335.80	20.13
C.300.70.15	250	70	15	1.5	4.86	6.20	567.76	36.58	45.42	21.68	6.89	9.57	2.43	16.9	125.0	295.18	13.41
C.300.70.20	250	70	15	2.0	6.44	8.10	749.20	47.82	59.94	27.79	9.06	9.62	2.43	17.2	125.0	335.80	20.13
C.300.70.24	250	70	15	2.4	7.70	9.62	891.59	56.48	71.33	32.52	10.73	9.63	2.42	17.4	125.0	356.11	25.40
C.300.70.30	250	70	15	3.0	9.57	11.90	1100.61	68.95	88.05	39.34	13.14	9.62	2.41	17.5	125.0	376.42	33.14

U TRACK SECTION - Available in standard track lengths 3 and 4 metres, heavy track also available in 2.5 and 3.0mm gauge.

dimensions					properties												
section reference	depth (Dmm)	flange (Wmm)	B Fl (Amm)	gauge (Tmm)	weight (kg/m)	area (cm ²)	I _{xx} (cm ⁴)	I _{yy} (cm ⁴)	Z _{xx} (cm ³)	Z _{yy1} (cm ³)	Z _{yy2} (cm ³)	R _{xx} (cm)	R _{yy} (cm)	PO (N/mm ²)	Mc (Nmm)		
U.104.50.12	104	50	50	1.2	1.92	2.46	42.19	5.92	8.11	4.85	1.57	4.14	1.55	417.51	3.39		
U.104.50.15	104	50	50	1.5	2.35	3.01	52.27	7.28	10.05	5.84	1.94	4.17	1.55	435.70	4.38		
U.104.70.20	104	70	70	2.0	3.70	4.73	89.50	24.11	17.21	11.73	4.88	4.35	2.26	453.90	7.81		
U.154.50.12	154	50	50	1.2	2.39	3.06	104.87	6.59	13.62	6.64	1.65	5.85	1.47	373.76	5.09		
U.154.50.15	154	50	50	1.5	2.94	3.76	130.23	8.10	16.91	8.00	2.03	5.88	1.47	400.71	6.78		
U.154.70.20	154	70	70	2.0	4.48	5.73	217.96	27.19	28.31	15.85	5.14	6.17	2.18	427.65	12.11		
U.204.50.12	204	50	50	1.2	2.86	3.66	205.29	7.04	20.13	8.38	1.69	7.49	1.39	330.01	6.64		
U.204.50.15	204	50	50	1.5	3.53	4.51	255.24	8.66	25.02	10.10	2.09	7.52	1.39	365.71	9.15		
U.204.70.20	204	70	70	2.0	5.26	6.73	418.91	29.36	41.07	19.91	5.31	7.89	2.09	401.41	16.49		
U.254.50.12	254	50	50	1.2	3.33	4.26	350.93	7.36	27.63	10.08	1.72	9.08	1.31	286.26	7.91		
U.254.50.15	254	50	50	1.5	4.11	5.26	436.67	9.05	34.38	12.14	2.13	9.11	1.31	330.71	11.37		
U.254.70.20	254	70	70	2.0	6.05	7.73	704.84	30.97	55.50	23.88	5.43	9.55	2.00	375.16	20.82		
U.304.50.12	304	50	50	1.2	3.80	4.86	549.30	7.61	36.14	11.75	1.75	10.63	1.25	242.52	8.76		
U.304.50.15	304	50	50	1.5	4.70	6.01	683.90	9.35	44.99	14.12	2.15	10.67	1.25	295.71	13.31		
U.304.70.20	304	70	70	2.0	6.83	8.73	1088.25	32.22	71.60	27.78	5.52	11.16	1.92	348.91	24.98		

To ensure that the correct through wall specification is designed, DSS provide full sectional dimensions for its range of products. The intention of these tables is to provide an approximate guide to designers to use in the early design stages.

C STUD SECTION						
dimensions						
section reference	depth (Dmm)	flange (Wmm)	B FI (mm)	return (Rmm)	B Lip (mm)	gauge (Tmm)
C.100.50.12	100	50	50	10	10	1.2
C.100.60.12	100	60	60	10	10	1.2
C.100.50.15	100	50	50	10	10	1.5
C.100.60.15	100	60	60	10	10	1.5
C.100.50.20	100	50	50	10	10	2.0
C.100.60.20	100	60	60	10	10	2.0
C.150.50.12	150	50	50	10	10	1.2
C.150.50.15	150	50	50	10	10	1.5
C.150.50.20	150	50	50	10	10	2.0
C.150.60.12	150	60	60	10	10	1.2
C.150.60.15	150	60	60	10	10	1.5
C.150.70.15	150	70	70	15	15	1.5
C.150.70.20	150	70	70	15	15	2.0
C.200.50.12	200	50	50	10	10	1.2
C.200.70.12	200	70	70	10	10	1.2
C.200.50.15	200	50	50	10	10	1.5
C.200.50.20	200	50	50	10	10	2.0
C.200.70.12	200	70	70	15	15	1.2
C.200.70.15	200	70	70	15	15	1.5
C.200.70.20	200	70	70	15	15	2.0
C.250.70.12	250	70	70	15	15	1.2
C.250.50.15	250	50	50	15	15	1.5
C.250.70.15	250	70	70	15	15	1.5
C.250.70.18	250	70	70	15	15	1.8
C.250.70.20	250	70	70	15	15	2.0
C.300.70.15	300	70	70	15	15	1.5
C.300.70.20	300	70	70	15	15	2.0
C.300.70.24	300	70	70	15	15	2.4
C.300.70.30	300	70	70	15	15	3.0

C STUD KEY POINTS:-

- Stud profiles denoted by 'C'.
- Standard stud available in 1.2, 1.5 and 2.0mm gauges.
- Heavy stud available in 2.5 and 3.0mm gauges
- Stud lengths are available up to 12 metres.

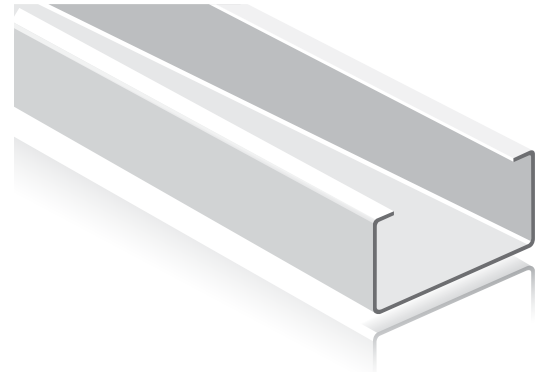
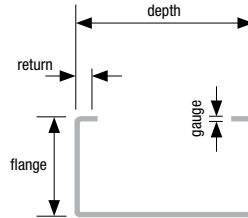

Glossary of terms

I_{xx}	Moment of inertia about	x-x axis
I_{yy}	Moment of inertia about	y-y axis
Z_{xx}	Elastic modulus about	x-x axis
Z_{xx1}	Elastic modulus about	y-y axis side 1
Z_{xx2}	Elastic modulus about	y-y axis side 2
R_{xx}	Radius of gyration about	x-x axis
R_{yy}	Radius of gyration about	y-y axis
PO	Design stress of section material	
Mc	Resistance moment of section @ design stress	

U TRACK SECTION				
dimensions				
section reference	depth (mm)	flange (mm)	B FI (mm)	gauge (mm)
U.104.50.12	104	50	50	1.2
U.104.50.15	104	50	50	1.5
U.104.70.20	104	70	70	2.0
U.154.50.12	154	50	50	1.2
U.154.50.15	154	50	50	1.5
U.154.70.20	154	70	70	2.0
U.204.50.12	204	50	50	1.2
U.204.50.15	204	50	50	1.5
U.204.70.20	204	70	70	2.0
U.254.50.12	254	50	50	1.2
U.254.50.15	254	50	50	1.5
U.254.70.20	254	70	70	2.0
U.304.50.12	304	50	50	1.2
U.304.50.15	304	50	50	1.5
U.304.70.20	304	70	50	2.0

U TRACK KEY POINTS:-

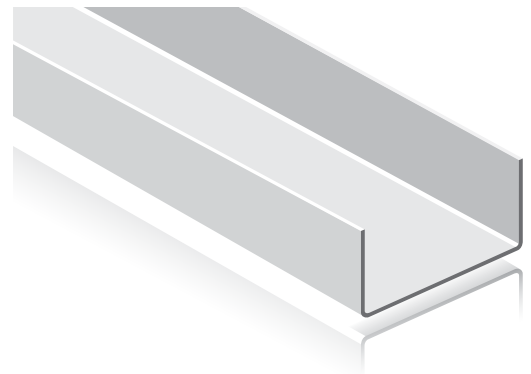
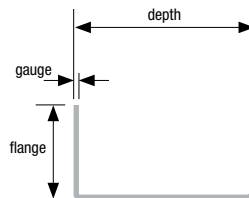

3 ACCESSORIES

A full range of standard SFS system accessories that also apply in cladding and rainscreen systems. Bespoke sections are also available to suit any type of design, produced using our CNC controlled pressbraking equipment, including the latest in 4m pressbrakes.

ACCESSORIES

Accessories manufactured from pre hot dipped galvanized material.

code/description	(mm)	gauge (mm)
Bracing Strap	100 width x 3000 length	1.2
Bracing Strap	100 width x 4000 length	1.2
Zed	40 x 40 x 40 x 3000 length	2.0
Angle	75 x 50 x 1.5 x 3000 length	1.5
Angle	75 x 50 x 2 x 3000 length	2.0
Angle	75 x 50 x 3 x 3000 length	3.0
Deflection Bracket DHB100	for 100 mm stud	1.2
Deflection Bracket DHB150	for 150 mm stud	1.2
Deflection Bracket DHB200	for 200 mm stud	1.2
Top Hat	50 x 50 x 50 x 3000 length	1.2

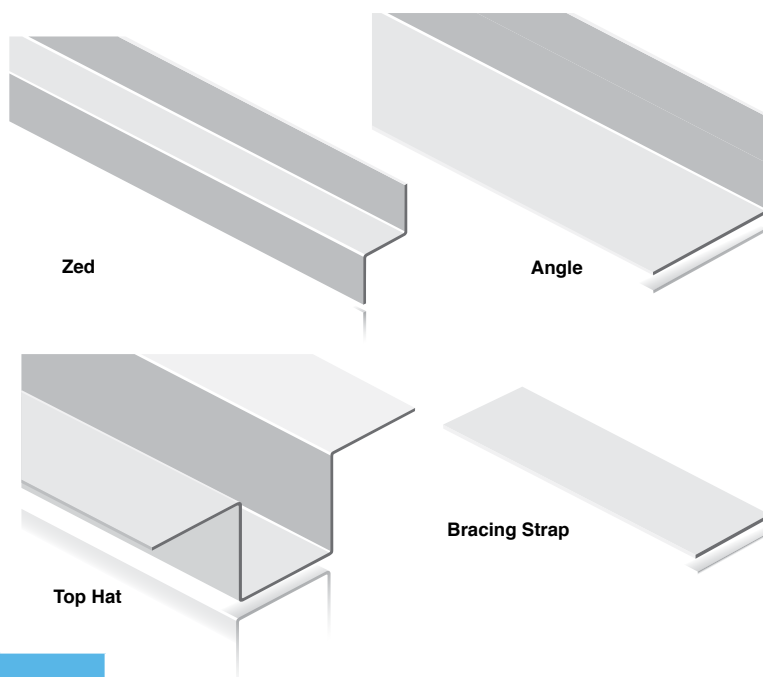

HEAVY GAUGE CHANNELS

Other channels from 0.5mm - 3.0mm up to 4m available upon request.

code	C x D x E (mm)	length (mm)	gauge (mm)	bundle	pack
DSC2	19 x 38 x 19	3600	1.6	10	100
DSC3	25 x 63 x 25	3600	1.6	n/a	100
DSC4	38 x 75 x 38	4200	1.6	n/a	100
DSC6	50 x 100 x 50	4800	1.6	n/a	50
DSC7	50 x 100 x 50	6000	1.6	n/a	50
DSC8	50 x 100 x 50	4800	2.0	n/a	50
DSC9	50 x 100 x 50	6000	2.0	n/a <td 50	

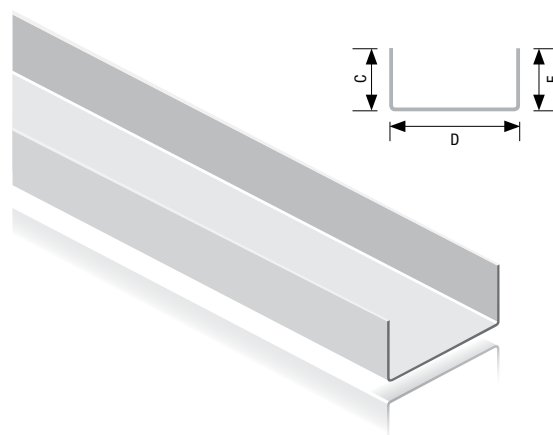

DRYWALL SCREWS

Black phosphate finish with Phillips countersunk head for fixing plasterboards to metal.

code	length (mm)	box quantity
DWS01	25	1000
DWS02	38	1000
DWS03	50	1000

WAFER HEAD SCREWS

Galvanized finish with Phillips low profile head and gimlet point for fixing metal to metal.

code	length (mm)	box quantity
DWS04	13	1000

FIXINGS TO CONCRETE For greater defined loads there are a range of heavy duty anchor bolts that will be specified, using market leading trade products. *

code/description

Tapcon Anchors 4H45

Steel Nail-in Anchor, M6 x 40 mm

FIXINGS TO STRUCTURAL STEEL *

Fine Thread Tek Screws THFP 38 00

Hilti EDNI - T Shot and Nail-in System

LIGHT GAUGE STEEL CONNECTIONS *

Wafer Head Tek Screws, 25mm

Pan Head Tek Screws, 25mm



* Project specific fixings will be detailed as part of the calculation package. Fixings will be detailed from the range of a market leading fixing supplier, complete with product specifications. **LINKS** - www.evolutionfasteners.co.uk - www.itwbuildex.com - www.hilti.co.uk

A SAMPLE SET OF TYPICAL SFS DETAILS,

showing some full system details that are supported from DSS light gauge steel sections.

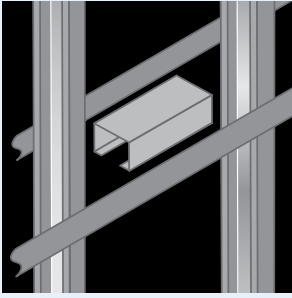

D Detail

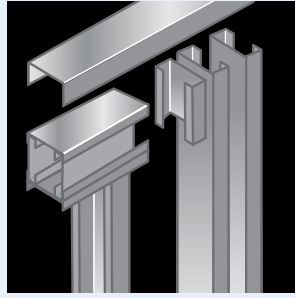

E Detail

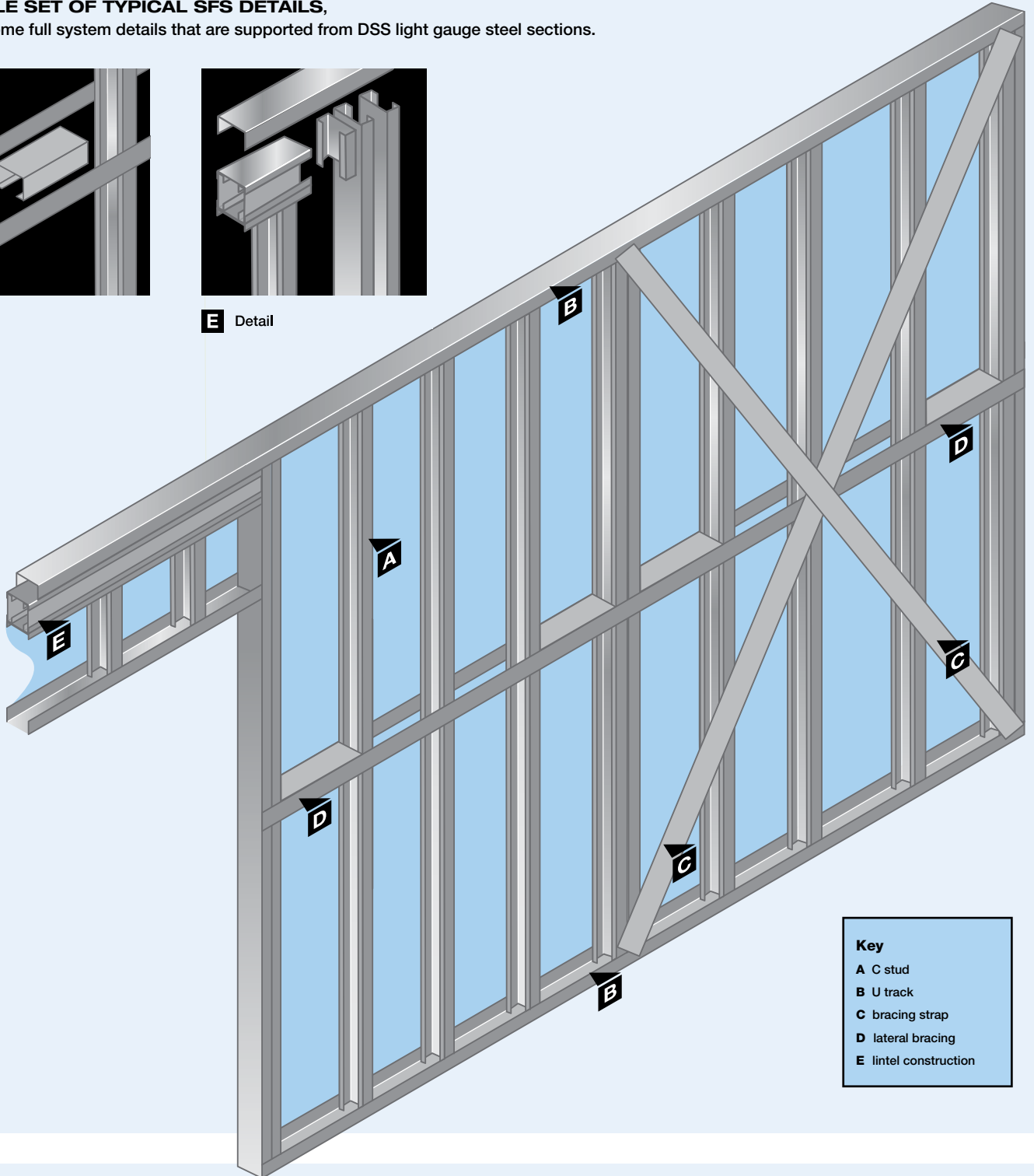

Key	
A	C stud
B	U track
C	bracing strap
D	lateral bracing
E	lintel construction

BLOCKING & BRACING DETAILS:-

Allowances need to be made within any SFS system for building movement. DSS can provide a variety of details and components including a bracing and blocking detail and an eaves detail to carry the SFS system.

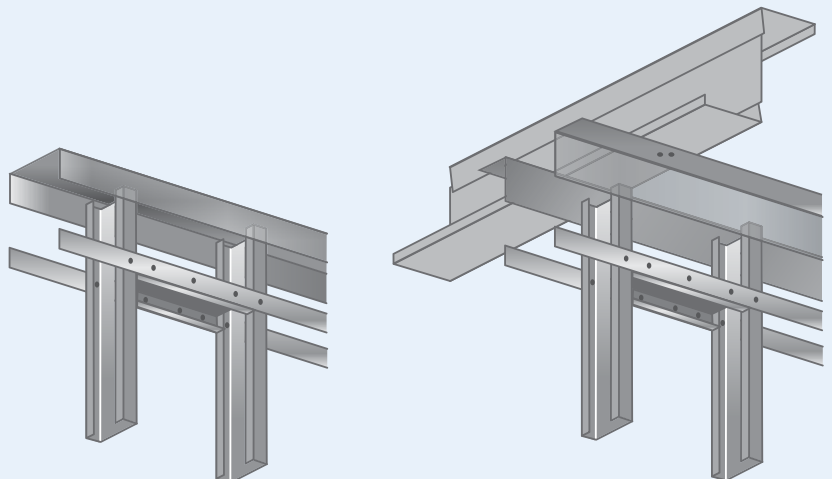

5 TYPICAL DETAILS

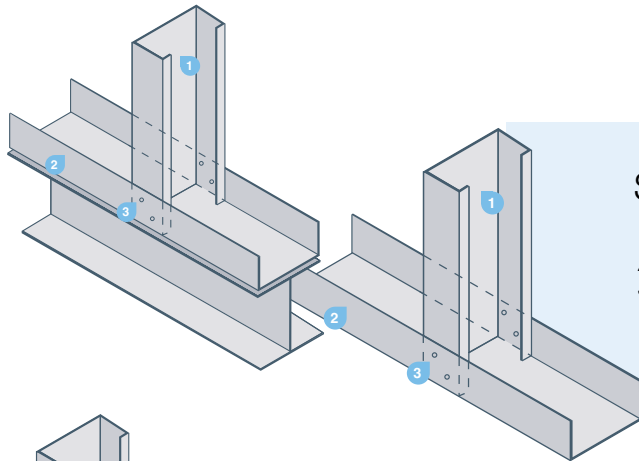

Stud Connection to Track

1. Stud
2. Track
3. Typically 1 No screw for each flange for infill walling. Typically 2 No screws for each flange for SFS loadbearing walls.

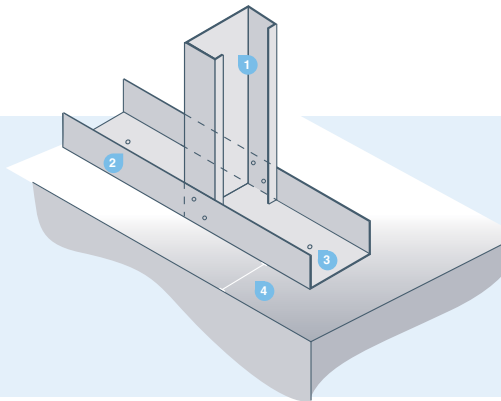

Screw Fixed Panel - Base Fixings to Concrete

1. Stud
2. Track
3. T/Fix to concrete with Tapcon anchors at 600mm centres or nails at 200mm centres
4. Refer to fixing guide for edge distances

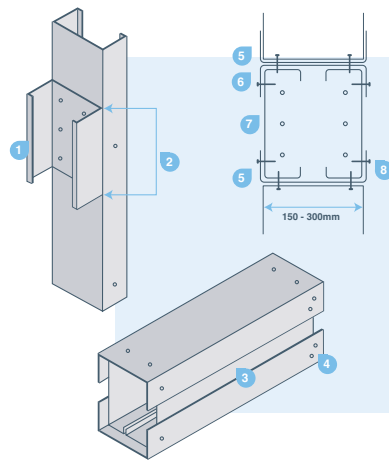

SFS Compound Lintel

1. Short section - see design for No. of screws to jamb
2. Equal to depth of back to back studs in lintel
3. Stud sections to be cut short by flange depth of short section
4. Fixings to be added after lintel is in position over short section
5. Track
6. Track (design may omit)
7. 2 No. studs
8. Indicates positions screws required at 300mm centres and maximum 150mm from each end.

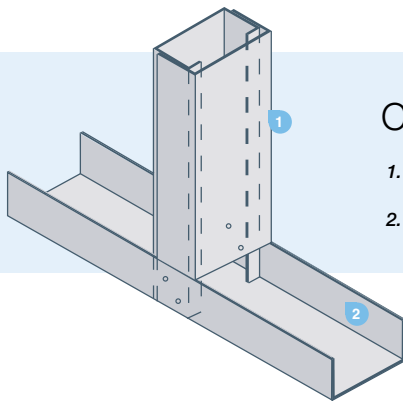

Compound member of Stud and Track

1. Track section fixed to stud with screws at a maximum of 300 centres at each flange
2. Base track

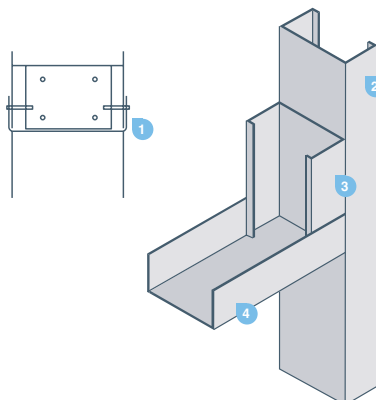

Track section Lintel

1. Track
2. Full height jamb stud
3. Min 150mm section fixed with 4 No screws
4. Track forming head to opening 2 No screws at each flange to stud

Blocking to Studs

1. VB38 lateral bracing on both sides. Note - joints between straps are to be butted together and not lapped
2. Solid blocking (of stud section) cut to fit tight between studs. Blocking typically every third bay but may be placed between every stud at teh request of design
3. 1 No. screw at each stud and 3 No. per blocking piece each flange

Restraint detail

4. Bracing channel to be fixed both sides of panels tooling into stud
5. At stud positions cut both flanges and flatten out. 2 No. screws to each stud

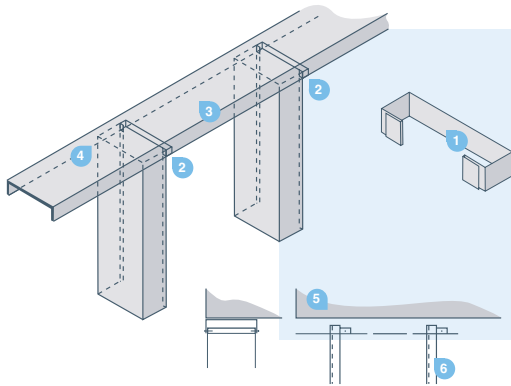
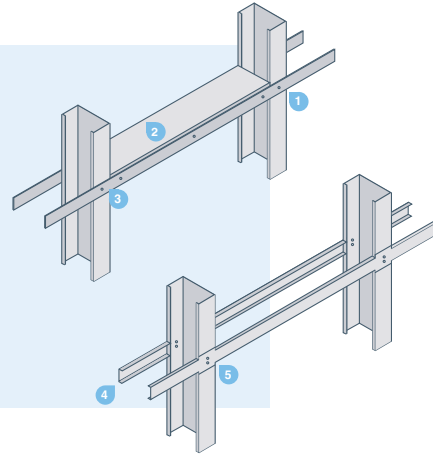

SFS Deflection Head type 3

1. Deflection bracket
2. Deflection bracket at every stud and fixed to track with 1 No. screws to each flange
3. Deep runner track
4. Stud must not be screwed to track. Top of stud 15 to 25mm below underside of track
5. Top track fixed to concrete/hot rolled frame at 600 centres
6. 15 - 25mm deflection gap between top of stud and underside of track

Double jamb with type 3 Deflection Head

1. Deflection bracket attached to jamb stud and cripple stud
2. Cripple stud extends to head track. Fix to jamb stud with 2 No. screws at 300mm vertical centres
3. Opening Lintel
4. Jamb stud. Example here is single jamb however compound jambs can be used
5. Opening Cill
6. Jamb stud. Example here is single jamb however compound jambs can be used
7. Cripple stud extends to base track. Fix to jamb stud with 2 No. screws at 300mm vertical centres
8. Jamb stud and cripple stud both fixed to base track

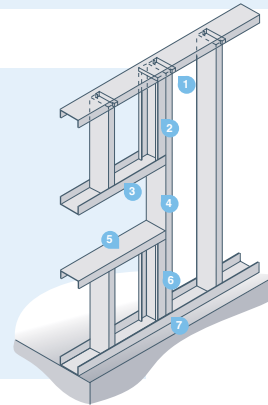

TRANSPORT & LOGISTICS 6



DELIVERY SERVICE *

Vehicle Capacity ranges				
Max. Length	6m	8m	9m	13.7m
Weight	3400kg	9500kg	15000kg	25000kg

* Please see our website for up-to-date pricing.

www.drywallsteelsections.co.uk

Nationwide delivery inc. Northern Ireland & Eire, on our own deidicated fleet of vehicles.

- Self offload facilities including HIAB/Moffett offloading service is available at an additional charge to the published transport rates.
- All deliveries where possible will be on a flat bed vehicle.
- Multiple deliveries can be accommodated at a minimum additional cost of £50 per delivery.
- Deliveries are between normal working hours. Deliveries outside of these times and be arranged at an additional cost.
- Customer timed delivery slots can be requested but no guarantee will be made for an exact delivery time.
- Any waiting time (demurrage) maybe subject to additional costs.

7 PARTITIONING & CEILING SYSTEMS

DRYWALL NON LOAD BEARING PARTITIONS

STUD & TRACK

Our lightweight drywall system is designed to produce easy to construct non load-bearing partitions. The range starts at 48mm to 146mm with track to suit in standard, deep and extra deep leg heights, and gauges from 0.5mm to 1.2mm.

C STUDS Other lengths, gauges and prices available upon application.

base (mm)	length (mm)	gauge (mm)
48, 50, 60, 70, 92 and 146	2400, 2700, 3000, 3600, 4200, 5000, 6000	0.5 to 1.2

U TRACK - 25mm to 70mm

base (mm)	length (mm)	gauge (mm)
50, 52, 62, 72, 94 and 148	3000 and 3600	0.5 to 1.2

I STUDS Other lengths, gauges and prices available upon request.

base (mm)	length (mm)	gauge (mm)
50, 60, 70, 92 and 146	2400, 2700, 3000, 3600, 4200, 5000, 6000	0.5 to 0.9

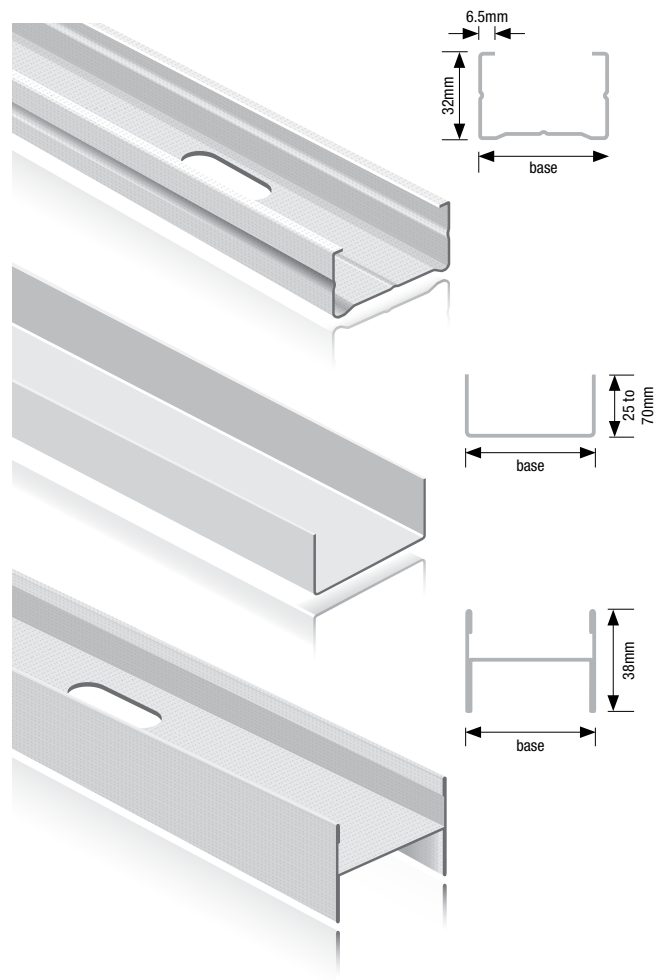

WALL LINER SYSTEM

Our lightweight wall liner system has been designed as an easy-to-use, economical method for lining internal walls. With a wide range of applications including residential, commercial and industrial the system is ideal to dry line, block and masonry walls and for concealing services.

WALL LINER CHANNELS

base (mm)	length (mm)	gauge (mm)
45	2400, 2700, 3000 and 3600	0.5

WALL LINER TRACKS

base (mm)	length (mm)	gauge (mm)
19	3000 and 3600	0.5

SMALL BRACKET

base (mm)	length (mm)	gauge (mm)
30	195	0.9

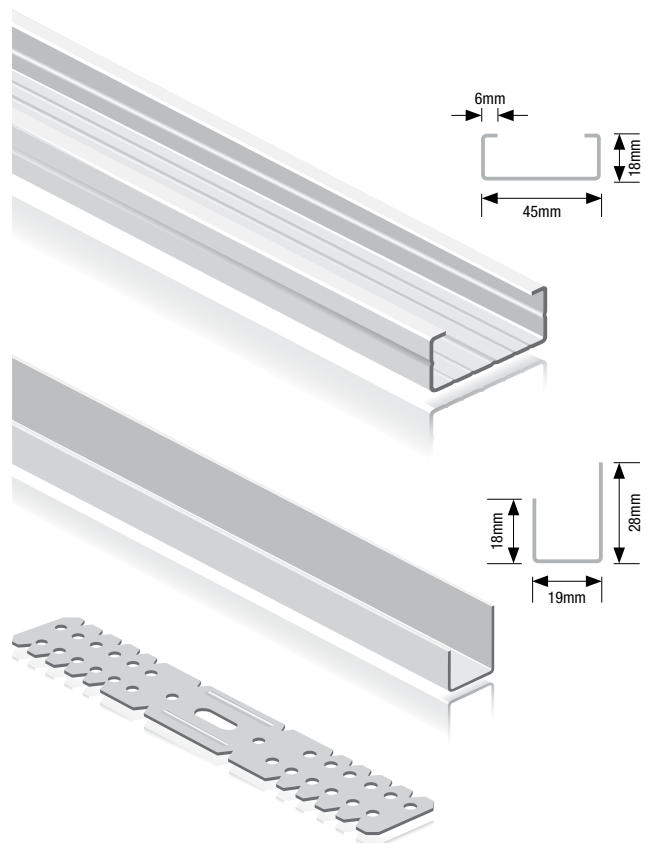

MF CEILING SYSTEM

Our MF ceiling system has a wide range of applications including both residential and commercial. It is ideally suited to where services are accommodated. It can be used to both upgrade and protect existing ceiling structures. Varying ceiling heights can be achieved to accommodate the varying ducting and services that are used in the market place today. Our MF ceiling system is compatible with all proprietary plasterboards.

CEILING CHANNEL

length (mm)	gauge (mm)
3600	0.5

PERIMETER CHANNEL

length (mm)	gauge (mm)
3600	0.5

PRIMARY CHANNEL

base (mm)	flange (mm)	length (mm)	gauge (mm)
45	15	3600	0.7

RESILIENT BAR

length (mm)	gauge (mm)
3000	0.5

ANGLE CLEAT

gauge (mm)
1.2



STRAP HANGER

length (mm)	gauge (mm)
25m	0.5



WIRE CLIP

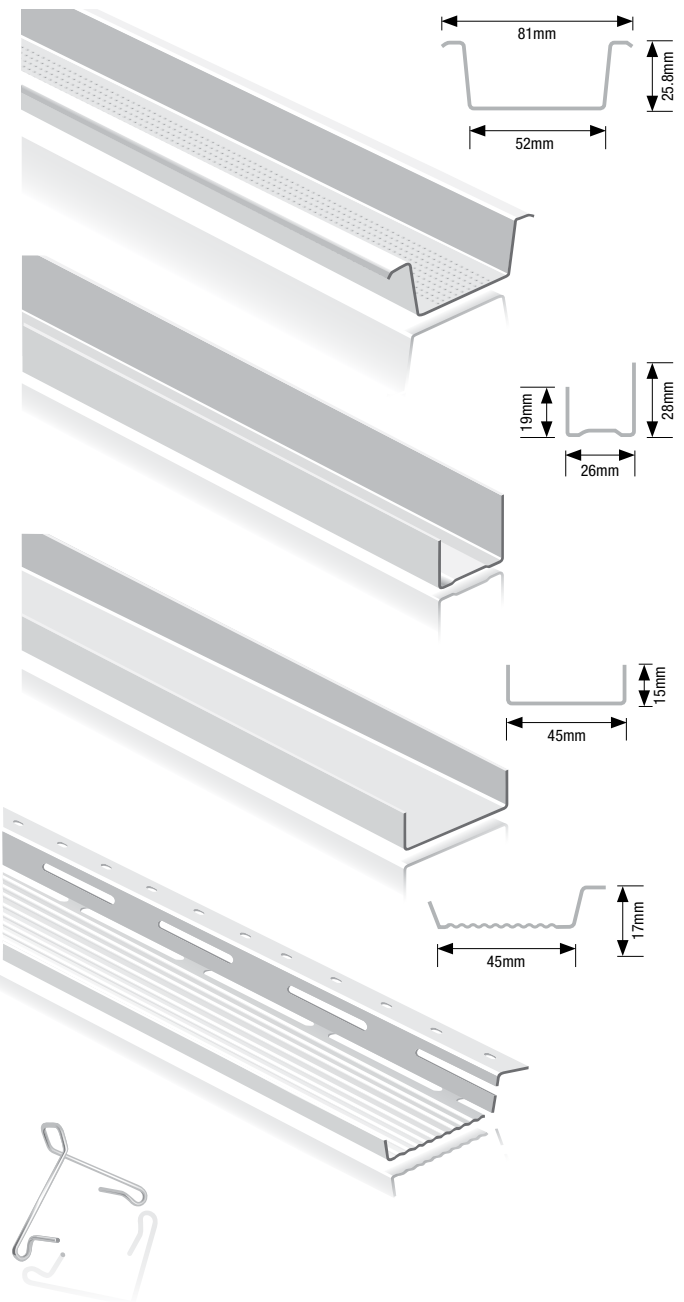

FIRE BARRIER

FIREBARRIER SLOTTED ANGLES

code	F (mm) x G (mm)	length (mm)	gauge (mm)	bundle	pack
DSFB1	50 x 50	3000	1.2	10	100
DSFB3	50 x 50	3000	2.0	10	100
DSFB4	60 x 40	3000	1.2	10	100
DSFB6	60 x 40	3000	2.0	10	100

FIREBARRIER SLOTTED STRAP

code	width (mm)	length (mm)	gauge (mm)	bundle	pack
DSFB7	40	3000	2.0	10	100

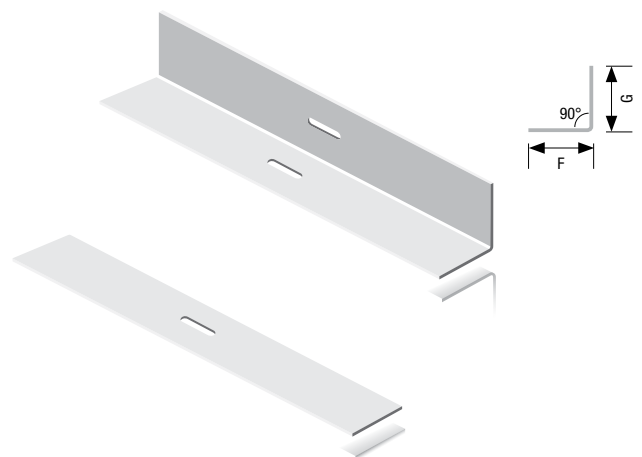

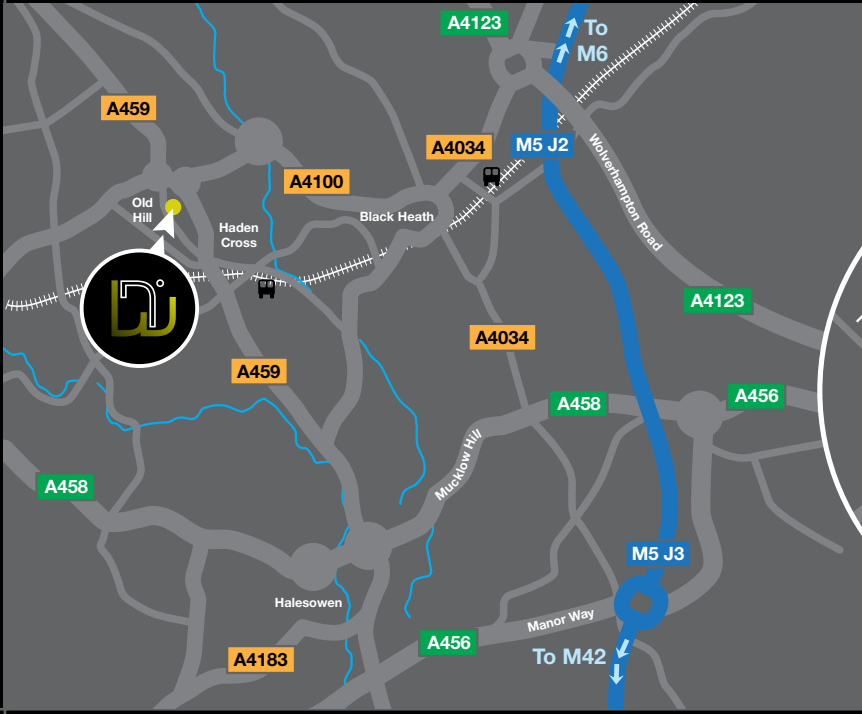

RELEVANT BRITISH STANDARDS

BS EN 10326:2004 & BS EN 10327:2004

All Drywall Steel Sections products are manufactured using materials that conform to the specification for continuously hot-dip metal coated steel.

BS EN 10143:1993

All Drywall Steel Sections products are manufactured to the specification for cold rolled steel

BS EN 7364:1990

All Drywall Steel Sections products are manufactured to, and comply with, the specification for, galvanized steel studs, channels for studs, sheet partitions and linings using screw fixed gypsum boards.

BS 476:Part 22:1987

Drywall Steel Sections have certification for their Drywall Stud & Track products that conform to BS 476:Part 22:1987 for fire testing on buildings and structures.

QUALITY ACCREDITATIONS

ISO 9001:2008

Drywall Steel Sections holds and operates a quality management system which complies with requirements of ISO:9001:2008 for the manufacture of cold rolled sections in ferrous, non-ferrous and alloy materials to customer specific or industry standards.

EN 1090-1:2009 + A1:2011

Drywall Steel Sections holds and operates a factory production control system certificate covering the manufacture (excluding welding) of structural work in steel up to and including Execution Class 2 (EXC 2) as defined in EN 1090-2.



Our products are marketed under the DSSL brands, which comply with all the relevant industrial standards, and through our Marketing and Technical Department, we offer bespoke sections manufactured to customers own specifications and brand labels.

Our mission is to establish DSSL as a leading low cost and innovative manufacturer of cold rolled metal ceiling and drywall systems, to give choice and added value to its customers, both home and abroad.



King Street
Cradley Heath
West Midlands
B64 6JH

Please contact us for more information

t + 44 (0) 1384 412448
f + 44 (0) 1384 410494
e enquiries@drywallsteelsections.co.uk

www.drywallsteelsections.co.uk